

PERFORMANCE SPECIFICATION SHEET

OSCILLATOR, CRYSTAL CONTROLLED, TYPE 1 (CRYSTAL OSCILLATOR (XO)),  
500 KHz THROUGH 85 MHz, HERMETIC SEAL, CMOS

This specification is approved for use by all Departments  
and Agencies of the Department of Defense.

The requirements for acquiring the product described herein  
shall consist of this specification sheet and [MIL-PRF-55310](#).

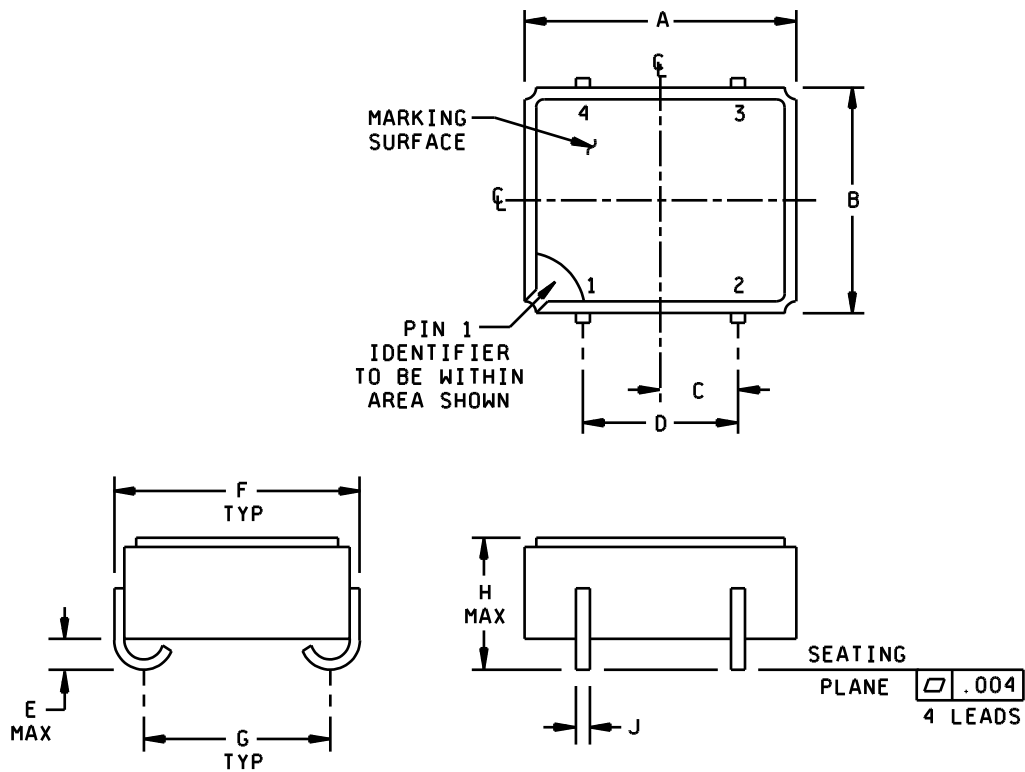

FIGURE 1. Interface and physical dimensions.

Pin number	Function
1	Enable/disable
2	GND
3	Output
4	B+

Ltr	Inches		mm	
	Min	Max	Min	Max
A	.345 Typ	.355 Typ	8.76 Typ	9.02 Typ
B	.285 Typ	.295 Typ	7.24 Typ	7.49 Typ
C	.086	.114	2.18	2.90
D	.195	.205	4.95	5.21
E	---	.040	---	1.02
F	---	.320	---	8.13
G	.232	.248	5.89	6.30
H	---	.170	---	4.32
J	.015	.021	0.38	0.53

NOTES:

1. Dimensions are in inches.
2. Metric equivalents are given for general information only.
3. Unless otherwise specified, tolerances are  $\pm 0.005$  (0.13 mm) for three place decimals and  $\pm 0.02$  (0.5 mm) for two place decimals.

FIGURE 1. Interface and physical dimensions - Continued.

## REQUIREMENTS:

Interface and physical dimensions: See [figure 1](#).

Mounting: See [figure 1](#).

Terminals: See [figure 1](#).

Seal: Hermetic in accordance with [MIL-PRF-55310](#), maximum leakage rate  $5 \times 10^{-8}$  atm cc/s.

Weight: 3 grams, maximum.

Oscillator: Class 2 or any class 1 or class 3 oscillator meeting all class 2 requirements and verification tests specified herein and in [MIL-PRF-55310](#).

Calibration: Manufacturer calibrated.

Screening: In accordance with [MIL-PRF-55310](#), product level B or S, as applicable.

Temperature:

Operating: See [table I](#).

Storage:  $-62^{\circ}\text{C}$  to  $+125^{\circ}\text{C}$ .

Load test circuit: See [figure 2](#).

Output waveform: Symmetrical square wave, 5 volt CMOS compatible (see [figure 3](#)).

Output logic voltage levels at designated CMOS (see [figure 3](#)):

Logic 1: 90 percent of  $V_{DD}$ , minimum.

Logic 0: 10 percent of  $V_{DD}$ , maximum.

Rise and fall times: (See [table I](#)) Measurements shall be taken at the 10 percent and 90 percent peak-to-peak output voltage levels, with peak-to-peak output defined as level 1-level 0 (see [figure 3](#)).

Duty cycle: See [table I](#) and [figure 3](#).

Supply voltage:  $+5.0\text{ V dc} \pm 10$  percent.

Input current: At designated supply voltage (see [table I](#)).

Enable/disable:

Output disabled (high impedance): Pin 1 input  $\leq 0.3\text{ V dc}$ .

Output active: Pin 1 input  $\geq 2.0\text{ V dc}$  or open.

Output frequency: Frequency as designated at time of acquisition (see [table I](#)).

Initial accuracy at reference temperature (up to 30 days after shipment): See [table I](#).

TABLE I. Dash numbers and operating characteristics.

Dash number	Output frequency range	Input current (max) <u>2/</u>	Pulse characteristics		Initial accuracy at +23°C ±1°C	Frequency-temperature tolerance (ppm) <u>1/</u>		
			Rise and fall times (max) <u>3/</u>	Duty cycle min-max <u>3/</u>		-55°C to +125°C	-55°C to +105°C	-20°C to +55°C
						A	B	C
01	500 kHz to 15.999 MHz	10 mA	6 ns	45% to 55%	±15 ppm	±50 ppm	±40 ppm	±25 ppm
04	500 kHz to 15.999 MHz	10 mA	6 ns	45% to 55%	±25 ppm	±100 ppm	±80 ppm	±50 ppm
11	16.000 MHz to 31.999 MHz	15 mA	5 ns	40% to 60%	±15 ppm	±50 ppm	±40 ppm	±25 ppm
14	16.000 MHz to 31.999 MHz	15 mA	5 ns	40% to 60%	±25 ppm	±100 ppm	±80 ppm	±50 ppm
21	32.000 MHz to 39.999 MHz	30 mA	5 ns	40% to 60%	±15 ppm	±50 ppm	±40 ppm	±25 ppm
24	32.000 MHz to 39.999 MHz	30 mA	5 ns	40% to 60%	±25 ppm	±100 ppm	±80 ppm	±50 ppm
31	40.000 MHz to 64.999 MHz	35 mA	3 ns	40% to 60%	±15 ppm	±50 ppm	±40 ppm	±25 ppm
34	40.000 MHz to 64.999 MHz	35 mA	3 ns	40% to 60%	±25 ppm	±100 ppm	±80 ppm	±50 ppm
41	65.000 MHz to 85.000 MHz	45 mA	3 ns	40% to 60%	±15 ppm	±50 ppm	±40 ppm	±25 ppm
44	65.000 MHz to 85.000 MHz	45 mA	3 ns	40% to 60%	±25 ppm	±100 ppm	±80 ppm	±50 ppm

1/ Temperature range A applicable for product level B oscillators only.

2/ Maximum input current for no load condition.

3/ See [figure 3](#).

Frequency-temperature tolerance (one-half temperature cycle, referenced to frequency measured at +23°C ±1°C, immediately prior to starting of the test): See table I. Measurements taken at ten equally spaced increments over the specified operating temperature range. 1/

Frequency-voltage tolerance: ±4 ppm maximum for a ±10 percent change in supply voltage. Measurements taken at reference temperature and operating temperature range end points.

Frequency aging: Measurements shall be taken at +70°C ±0.2°C at intervals of not more than every 72 hours for 30 days minimum (Except one maximum interval of 96 hours per 30 days is permitted).

±10 ppm per year, maximum.

±1.5 ppm per 30 days.

±3 ppm per 90 days.

1/ For the purpose of transitioning this device to [MIL-PRF-55310](#), 'Frequency stability versus temperature' has been renamed 'Frequency-temperature tolerance'. The verification requirements of 'initial frequency-temperature accuracy (one-half temperature cycle)' shall apply except that frequency measurements shall be referenced to the frequency measured at +23°C ±1°C ( $f_{ref}$ ) instead of to the nominal frequency ( $f_{nom}$ ).

Terminal strength: [Method 211 of MIL-STD-202](#), test condition A.

Applied force: 8 ounces each terminal.

Frequency-environmental tolerance: Not applicable.

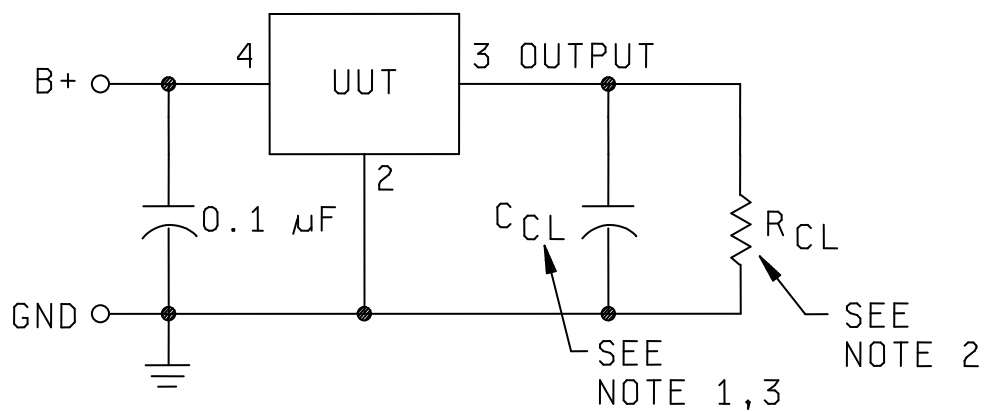

NOTES:

1. For  $C_{CL} = 15 \text{ pF} \pm 5 \text{ percent}$ .
2. For  $R_{CL} = 10 \text{ k}\Omega \pm 5 \text{ percent}$ .
3.  $C_{CL}$  includes scope capacitance.

FIGURE 2. Load test circuit.

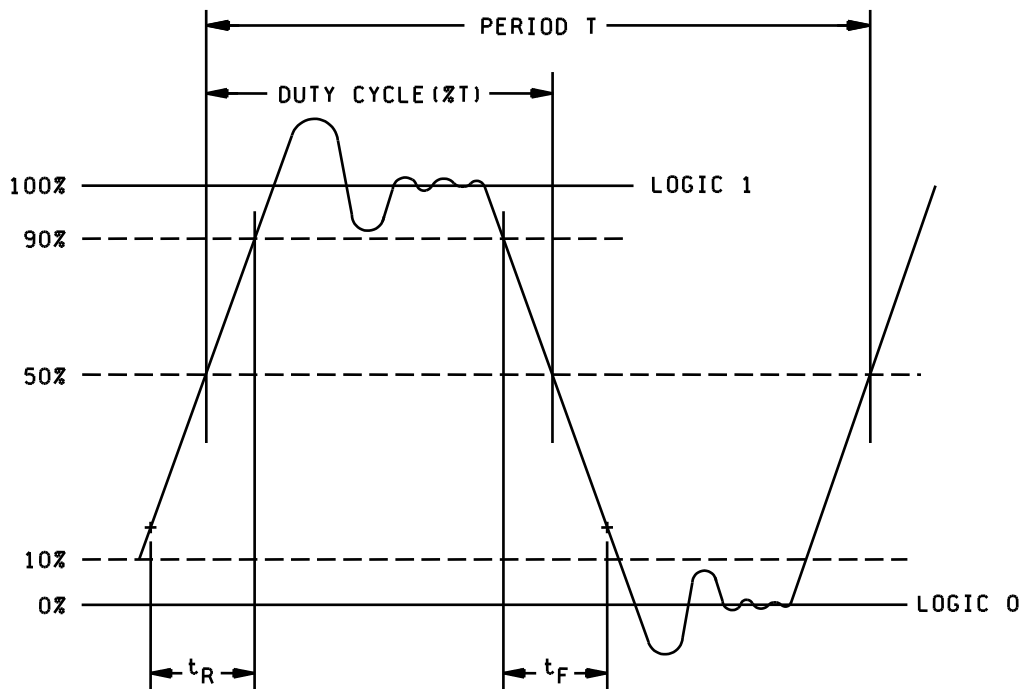
FIGURE 3. Waveform

Vibration, sinusoidal: In accordance with [MIL-PRF-55310](#) and [method 204 of MIL-STD-202](#).

Nonoperating: Test condition G.

Operating: Not required.

Ambient pressure:

Nonoperating: In accordance with [MIL-PRF-55310](#).

Operating: [Method 105 of MIL-STD-202](#), test condition C.

Exposure time: 5 minutes.

Reflow soldering: Reflow soldering of the unit at  $+230^{\circ}\text{C} \pm 10^{\circ}\text{C}$  for 15 seconds shall not degrade the performance.

MIL-PRF-55310/33C

Part or Identifying Number (PIN): Consists of "M" prefix followed by specification sheet number, a dash and coded alphas, and numeric number. See example:

EXAMPLE

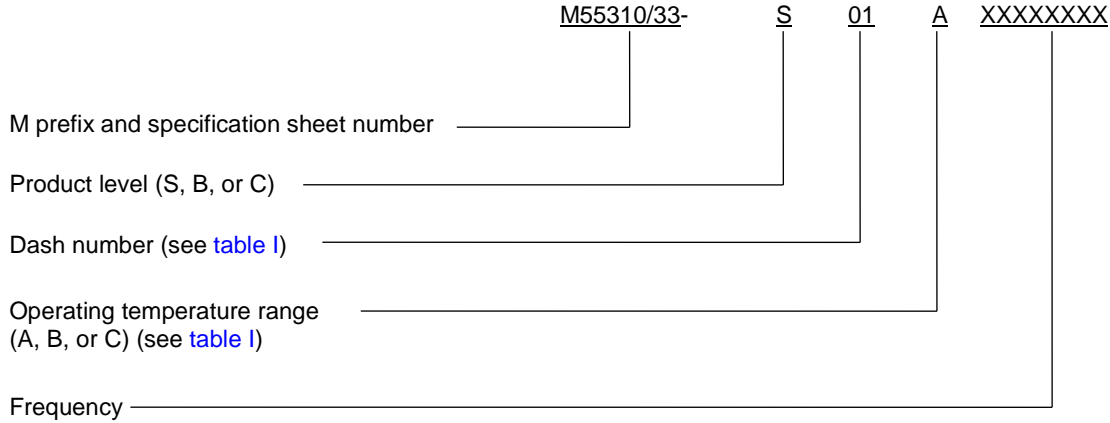

Referenced documents. In addition to MIL-PRF-55310, this document references MIL-STD-202.

The margins of this specification are marked with vertical lines to indicate where changes from the previous issue were made. This was done as a convenience only and the Government assumes no liability whatsoever for any inaccuracies in these notations. Bidders and contractors are cautioned to evaluate the requirements of this document based on the entire content irrespective of the marginal notations and relationship to the last previous issue.

Custodians:  
Army - CR  
Navy - EC  
Air Force - 99  
DLA - CC

Preparing activity:  
Army - CR  
Agent:  
DLA - CC

Review activities:  
Army - AR, MI, SM  
Navy - AS, CG, MC  
Air Force - 19  
NASA - NA

(Project 5955-2013-001)

NOTE: The activities listed above were interested in this document as of the date of this document. Since organizations and responsibilities can change, you should verify the currency of the information above using the ASSIST Online database at <https://assist.dla.mil>.