



**“XE10-L00” Series ( LVHCMOS), 3.3 VDC**  
**High Reliability Hybrid Microcircuit Crystal Oscillators**  
*( Low Profile Surface Mount LCC Package )*

**Features**

- Ruggedized 4 Point Crystal Mount
- Tristate Output Option
- Radiation Tolerant to 10K Rads
- 100% Screening Options
- Low Phase Noise
- Hermetically Sealed, Ceramic Package
- ECCN: EAR99

**Applications**

- High Shock & Vibration Applications
- Navigation Systems
- Aerospace Instrumentation
- Benign Space Applications
- Gun Launched Munitions

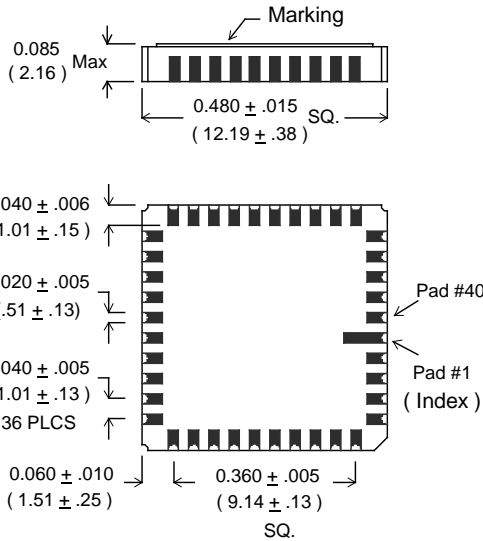

PAD#	FUNCTION
4 & 10	Vdd
31 & 37	GND/CASE
32	E/D (Optional)
39	OUTPUT
All Others	N/C

**Package Specifications & Outline:**

- Package: Ceramic 90% AL<sub>2</sub>O<sub>3</sub>
- Seal: Hermetic – Resistance Welded
- Weight: 0.9 Gms typical, 1.2 Gms Max.
- Thermal Resistance, Junction to Case ( θ<sub>JC</sub> ): 30 °C / Watt
- Solder Reflow, Temp./Time: 260 °C, 10 Secs. Max.
- Terminations Material & Finish: Tungsten, 50 to 80 μ inches gold over 100 to 250 μ inches Nickel

Dimensions: Inches (mm)

**E/D ( Enable/Disable ) Input:** A “Low” level at the input disables the Output into a high impedance state.

E/D Input has internal pull-up. It can be left floating or connected to Vdd.

Hot Solder Tinning per MIL-PRF-55310 is optional at additional cost.

Contact Xsis Electronics at [xisis@xisis.com](mailto:xisis@xisis.com) for any special requirements.

**ORDERING INFORMATION ( Please build your part number from options below ) :**

**P/N EXAMPLE: XE10 – L43G – 883B – 24.000 MHz = 3.3V LVHCMOS, ± 50 PPM over -55 °C to +125 °C, Tristate Output, 883B Screening, 24.000 MHz**

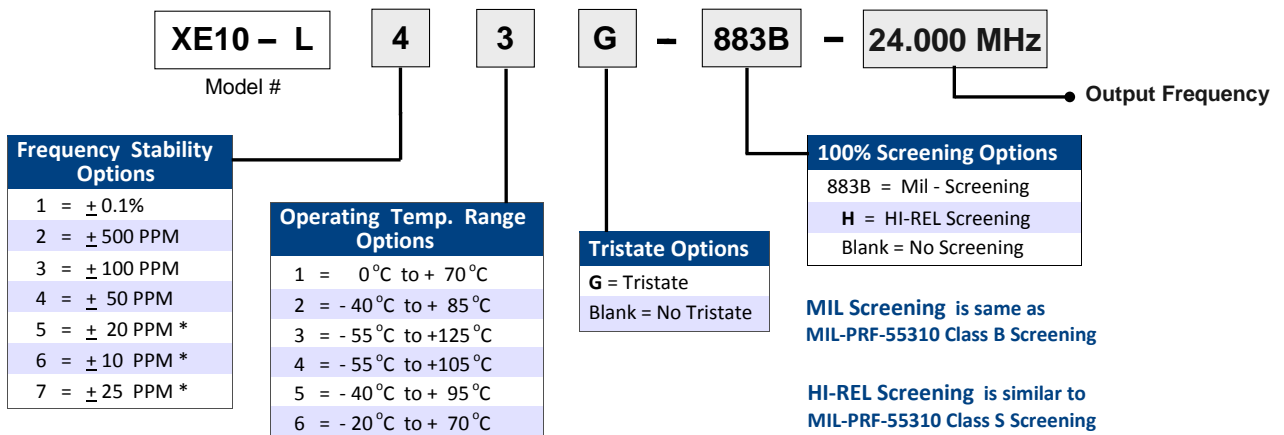

\* Frequency Stability Options 5, 6 & 7 are not available for all operating temperature ranges.

**MIL Screening is same as MIL-PRF-55310 Class B Screening**

**HI-REL Screening is similar to MIL-PRF-55310 Class S Screening**



**“XE10-L00” Series ( LVHCMOS), 3.3 VDC**  
**High Reliability Hybrid Microcircuit Crystal Oscillators**  
**( Low Profile Surface Mount LCC Package )**

**Electrical Specifications:**

Parameter	Specification Limits
Output Frequency Range	200 KHz - 100 MHz
Frequency Accuracy at +25 °C	± 15 PPM
Frequency Stability Vs Temperature	See Ordering Information on Page 1
Operating Temperature Range	See Ordering Information on Page 1
Supply Voltage (Vdd)	+ 3.3 VDC ± 10%
Input Current ( no Load )	200 KHz - 8 MHz 3 mA Max. 8.1 MHz - 16 MHz 6 mA Max. 16.1 MHz - 32 MHz 10 mA Max. 32.1 MHz - 60 MHz 20 mA Max. 60.1 MHz - 100 MHz 30 mA Max.
Output Waveform	Square Wave, HC/ACMOS Compatible
Output Duty Cycle ( at 50% Output Level )	< 30 MHz 55/45% Max. ≥ 30 MHz 60/40% Max.
Output High Level	0.9 Vdd Min.
Output Low Level	0.1 Vdd Max.
Output Load	10 KΩ // 15 pf
Rise & Fall Times ( Typical Load )	< 30 MHz 6 nS Max. ≥ 30 MHz 3 nS Max. ( 10% to 90% Output Levels)
Enable/Disable ( E/D)	E/D Input ≥ 3.5V or Open : Normal Output E/D Input ≤ 0.8V: High Impedance
Start-Up Time	10 mS Max.
Phase Jitter ( 10 KHz - 20 MHz Integrated )	0.15 pS rms Typical
Freq. Stability Vs Supply Voltage	± 5 PPM Max. for ± 10% change in Supply Voltage
Aging at 70 °C	± 3 PPM Max. first year, ± 2 PPM Max. per year thereafter
Absolute Maximum Applied Voltage	+ 5VDC
Storage Temperature	-65 °C to +125 °C

***For special requirements, such as, tighter output symmetry, faster start-up time, PIND screening, etc., please contact Xsis Electronics at [xisis@xisis.com](mailto:xisis@xisis.com) or call us at 913-631-0448.***



**“XE10-L00” Series ( LVHCMOS), 3.3 VDC**  
**High Reliability Hybrid Microcircuit Crystal Oscillators**  
*( Low Profile Surface Mount LCC Package )*

**Packaging:** ESD protective Enclosed tray. Tape & Reel packaging is available at additional cost.

**Thermal Characteristics:**

Junction to case Thermal Constant (  $\theta_{JC}$  ): 30 °C / Watt

Junction to Ambient ( Device floating in free air) Thermal Constant (  $\theta_{JA}$  ): 110 °C / Watt

**Hi-Rel Screening:**

When HI-REL option is selected, Xsis Oscillators are subjected to 100% screening similar to Class “S” screening in accordance with MIL-PRF-55310. Refer to [www.xsis.com](http://www.xsis.com) for additional details about HI-REL screening.

**Typical Phase Noise (dbc/Hz):**

Output Frequency	10 Hz	100 Hz	1 KHz	10 KHz	100 KHz	1 MHz
10 MHz	-109	-140	-157	-162	-163	-164
25 MHz	-100	-127	-151	-158	-160	-162
50 MHz	-89	-117	-148	-157	-159	-160
96 MHz	-80	-107	-139	-151	-156	-158
100 MHz	-77	-104	-133	-145	-151	-155

**Environmental Specifications:**

XE10-L00 series oscillators are designed to meet or exceed the Environmental tests specified below. Customized screening and environmental testing are also available to meet your special requirements.

Test	Test Conditions
Vibration	0.06” DA, 30 G peak, 10 - 2000 Hz, MIL-STD-202, Method 204, Cond. G
Shock	1500 G, 0.5 mS, half-Sine, MIL-STD-883, Method 2002, Cond. B
Temperature Cycling	MIL-STD-883, Method 1010, Cond. C
Thermal Shock	MIL-STD-202, Method 107, Cond. B
Seal ( Fine and Gross )	MIL-STD-883, Method 1014 Cond. A & C
Burn-in	160 Hours, 125 °C, Nominal Supply Voltage & Load
Frequency Aging	30 days at 70 °C, ± 1.5 PPM Max.
Altitude	MIL-STD-202, Method 105, Cond. C
Constant Acceleration	MIL-STD-883, Method 2001, 5000 G
Moisture Resistance	MIL-STD-202, Method 106, Vibration Sub Cycle Omitted
Solderability	MIL-STD-202, Method 208
Resistance to Soldering Heat	MIL-STD-202, Method 210, Cond B. or C as applicable
Resistance to Solvents	MIL-STD-202, Method 215
Internal Water Vapor Content	MIL-STD-883, Method 1018
ESD Classification	MIL-STD-883, Method 3015, Class 1C, HBM 1000 to 1999
Moisture Sensitivity Level	J-STD-020, MSL=1



**“XE10-L00” Series ( LVHCMOS), 3.3 VDC**  
**High Reliability Hybrid Microcircuit Crystal Oscillators**  
*( Low Profile Surface Mount LCC Package )*

**HCMOS Test Circuit**

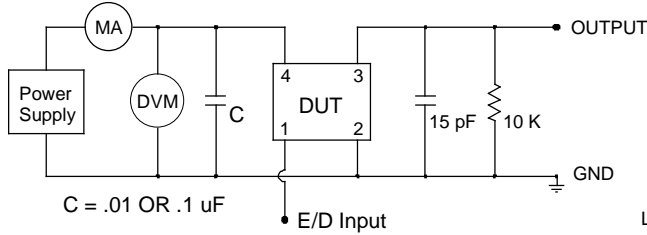

**E/D ( Enable/Disable ) Input** has an internal pull-up resistor. It can be left floating or connected to Vdd.

**HCMOS Output Waveform**

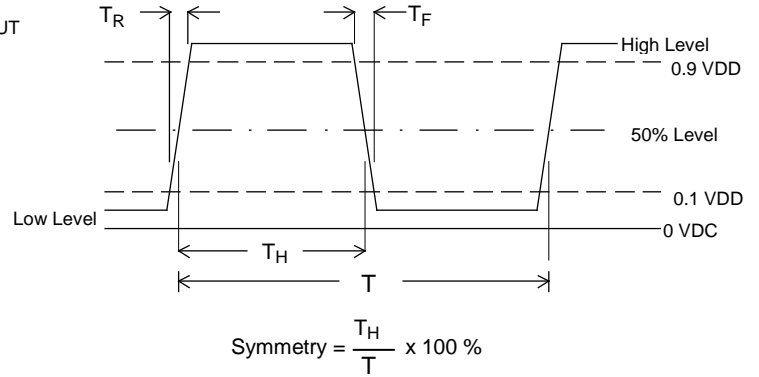

**Typical Freq. Stability Vs. Temperature**

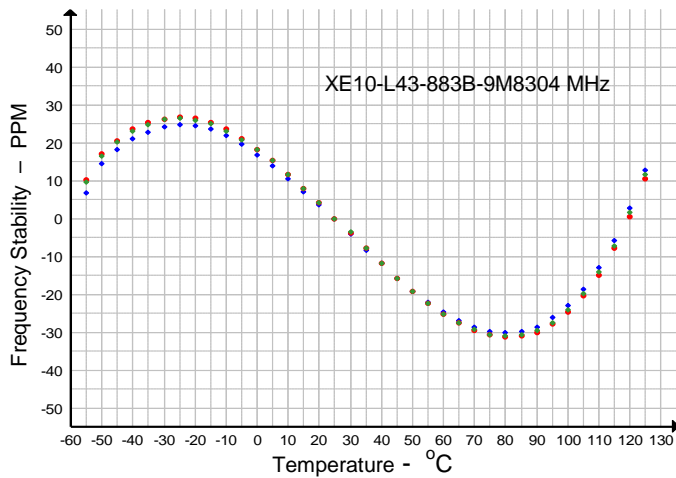

**Tape & Reel Information**

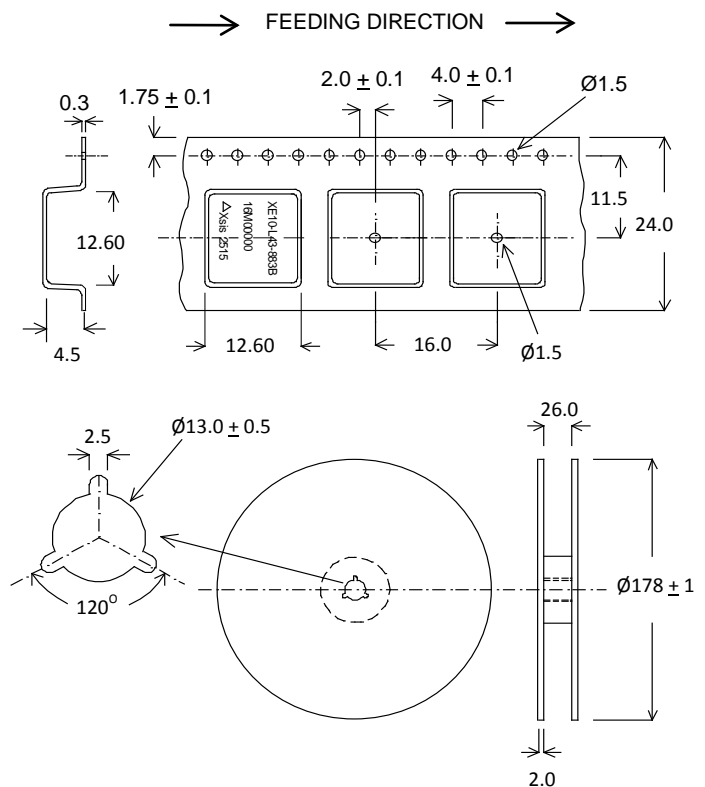

Dimensions are in mm.

**Tape is EIA-481-A Compliant.**

**Typical Solder Reflow Profile**

