

PERFORMANCE SPECIFICATION SHEET

OSCILLATOR, CRYSTAL CONTROLLED, TYPE 1 (CRYSTAL OSCILLATOR (XO)),
450 KHz THROUGH 100 MHz, HERMETIC SEAL, LOW VOLTAGE CMOS

This specification is approved for use by all Departments
and Agencies of the Department of Defense.

The requirements for acquiring the product described herein
shall consist of this specification sheet and [MIL-PRF-55310](#).

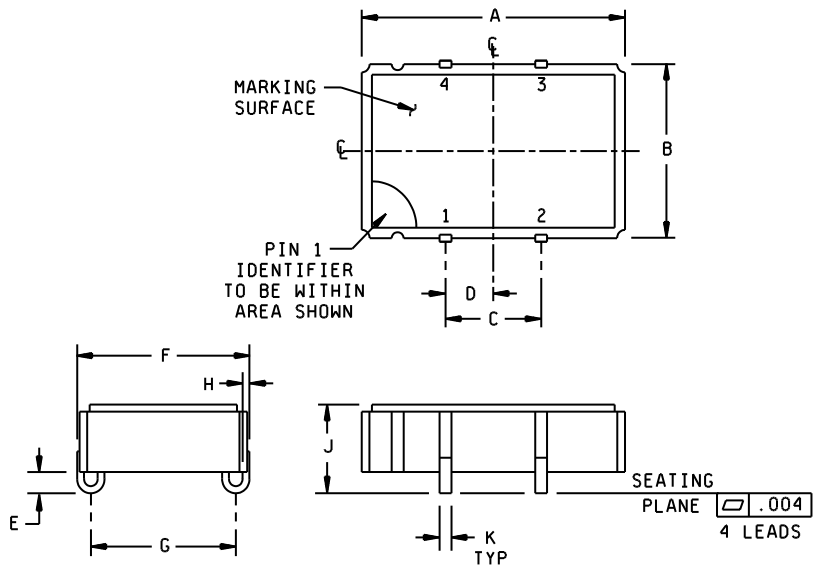

Pin number	Function
1	Enable/Disable
2	GND
3	Output
4	V _{DD}

Ltr	Inches		mm	
	Min	Max	Min	Max
A	N/A	.560	N/A	14.22
B	N/A	.360	N/A	9.14
C	.195	.205	4.95	5.21
D	.086	.114	2.18	2.90
E	.025	.055	.635	1.40
F	N/A	.378	N/A	9.60
G	.292	.308	7.42	7.82
H	.007	.009	.178	.229
J	N/A	.188	N/A	4.78
K	.015	.021	.381	.533

NOTES:

1. Dimensions are in inches.
2. Metric equivalents are given for general information only.
3. Unless otherwise specified, tolerances are ± 0.005 (0.13 mm) for three place decimals and ± 0.02 (0.5 mm) for two place decimals.

FIGURE 1. Dimensions and configuration.



REQUIREMENTS:

Interface and physical dimensions: See [figure 1](#).

Mounting: See [figure 1](#).

Pads: See [figure 1](#).

Seal: Hermetic in accordance with [MIL-PRF-55310](#), maximum leakage rate 5×10^{-8} atm cc/s.

Weight: 3 grams, maximum.

Oscillator: Class 2 or any class 1 or class 3 oscillator meeting all class 2 requirements and verification tests specified herein and in [MIL-PRF-55310](#).

Calibration: Manufacturer calibrated.

Screening: In accordance with [MIL-PRF-55310](#), product level B or S, as applicable.

Temperature:

Operating: See [table I](#).

Storage: -62°C to +125°C.

Load test circuit: See [figure 2](#).

Output waveform: Symmetrical square wave, 3.3 volt CMOS logic compatible (see [figure 3](#)).

Output logic voltage levels at designated CMOS (see [figure 3](#)):

Logic 1: 90 percent of V_{DD} , minimum.

Logic 0: 10 percent of V_{DD} , maximum.

Rise and fall times: (See [table I](#)) Measurements shall be taken at the 10 percent and 90 percent peak-to-peak output voltage levels, with peak-to-peak output defined as level 1-level 0 (see [figure 3](#)).

Duty cycle: See [table I](#) and [figure 3](#).

Supply voltage: +3.3 V dc \pm 10 percent.

Input current: At designated supply voltage (see [table I](#)).

Enable/disable:

Output disabled (high impedance): Pin 1 input \leq 0.3 V dc.

Output active: Pin 1 input \geq 2.0 V dc or open.

Output frequency: Frequency as designated at time of acquisition (see [table I](#)).

Initial accuracy at reference temperature (up to 30 days after shipment): See [table I](#).

TABLE I. Dash numbers and operating characteristics.

Dash number	Output frequency range	Input current (max) ^{1/}	Pulse characteristics		Initial accuracy at +23°C ±1°C	Frequency-temperature tolerance (ppm)		
			Rise and fall times (max) ^{2/}	Duty cycle min-max ^{2/}		-55°C to +125°C	-55°C to +105°C	-20°C to +70°C
						A	B	C
01	450 kHz to 14.999 MHz	8 mA	10 ns	45% to 55%	±15 ppm	±50 ppm	±40 ppm	±25 ppm
04	450 kHz to 14.999 MHz	8 mA	10 ns	45% to 55%	±25 ppm	±100 ppm	±80 ppm	±50 ppm
11	15.000 MHz to 29.999 MHz	10 mA	10 ns	45% to 55%	±15 ppm	±50 ppm	±40 ppm	±25 ppm
14	15.000 MHz to 29.999 MHz	10 mA	10 ns	45% to 55%	±25 ppm	±100 ppm	±80 ppm	±50 ppm
21	30.000 MHz to 59.999 MHz	20 mA	5 ns	40% to 60%	±15 ppm	±50 ppm	±40 ppm	±25 ppm
24	30.000 MHz to 59.999 MHz	20 mA	5 ns	40% to 60%	±25 ppm	±100 ppm	±80 ppm	±50 ppm
31	60.000 MHz to 85.000 MHz	30 mA	3 ns	40% to 60%	±15 ppm	±50 ppm	±40 ppm	±25 ppm
34	60.000 MHz to 85.000 MHz	30 mA	3 ns	40% to 60%	±25 ppm	±100 ppm	±80 ppm	±50 ppm
41	85.000 MHz to 100.00 MHz	30 mA	3 ns	40% to 60%	±15 ppm	±50 ppm	±40 ppm	±25 ppm
44	85.000 MHz to 100.00 MHz	30 mA	3 ns	40% to 60%	±25 ppm	±100 ppm	±80 ppm	±50 ppm

^{1/} Maximum input current for no load condition.

^{2/} See figure 3.

Frequency-temperature tolerance (one-half temperature cycle, referenced to frequency measured at +23°C ±1°C, immediately prior to starting of the test): See table I. Measurements taken at ten equally spaced increments over the specified operating temperature range. ^{1/}

Frequency-voltage tolerance: ±4 ppm maximum for a ±10 percent change in supply voltage. Measurements taken at reference temperature and operating temperature range end points.

Frequency aging: Measurements shall be taken at +70°C ±0.2°C at intervals of not more than every 72 hours for 30 days minimum.

±10 ppm per year, maximum

±1.5 ppm per 30 days.

±3 ppm per 90 days.

Terminal strength: MIL-STD-202-211, test condition A.

Applied force: 8 ounces each terminal.

Frequency-environmental tolerance: Not applicable.

^{1/} For the purpose of transitioning this device to MIL-PRF-55310, 'Frequency stability versus temperature' has been renamed 'Frequency-temperature tolerance'. The verification requirements of 'initial frequency-temperature accuracy (one-half temperature cycle)' shall apply except that frequency measurements shall be referenced to the frequency measured at +23°C ±1°C (f_{ref}) instead of to the nominal frequency (f_{nom}).

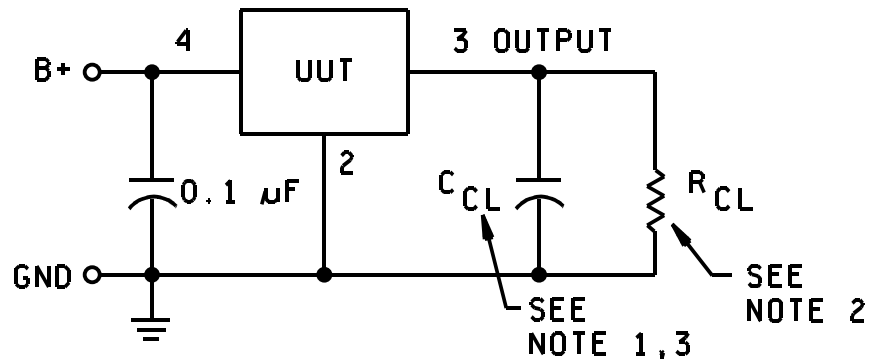

NOTES:

1. For C_{CL} = 15 pF ±5 percent.
2. For R_{CL} = 10 kΩ ±5 percent.
3. C_{CL} includes scope capacitance.

FIGURE 2. Load test circuit.

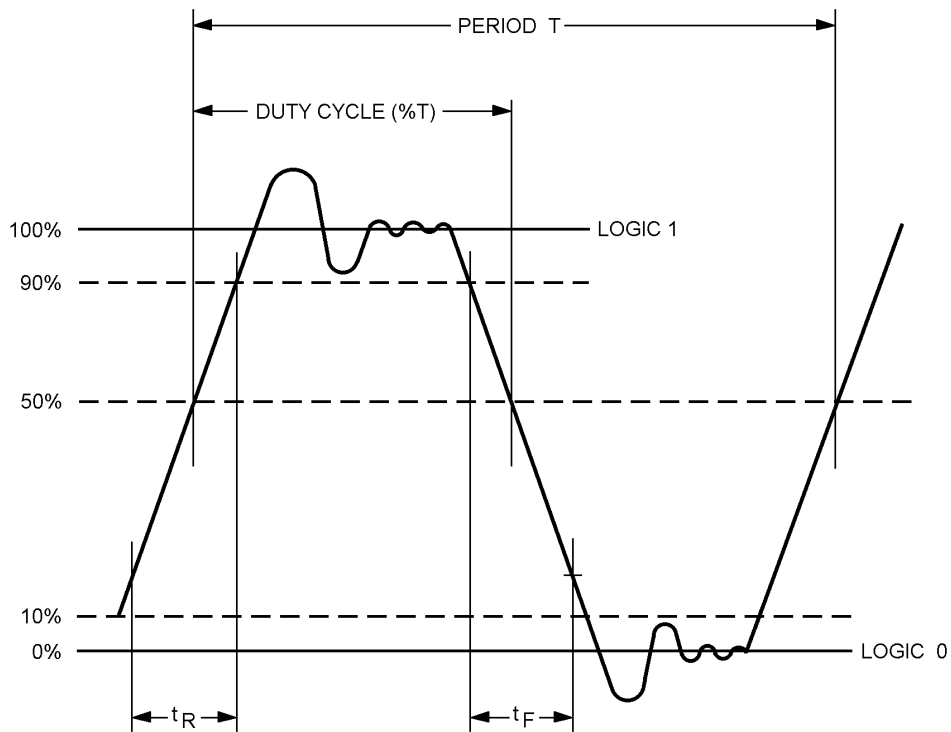

FIGURE 3. Waveform

MIL-PRF-55310/30E

Vibration, sinusoidal: In accordance with [MIL-PRF-55310](#) and [MIL-STD-202-204](#).

Nonoperating: Test condition D.

Operating: Not required.

Ambient pressure:

Nonoperating: In accordance with [MIL-PRF-55310](#).

Operating: [MIL-STD-202-105](#), test condition C.

Exposure time: 5 minutes.

Reflow soldering: Reflow soldering of the unit at +230°C ±10°C for 15 seconds shall not degrade the performance.

Part or Identifying Number (PIN): Consists of "M" prefix followed by specification sheet number, a dash and coded alphas, and numeric number. See example:

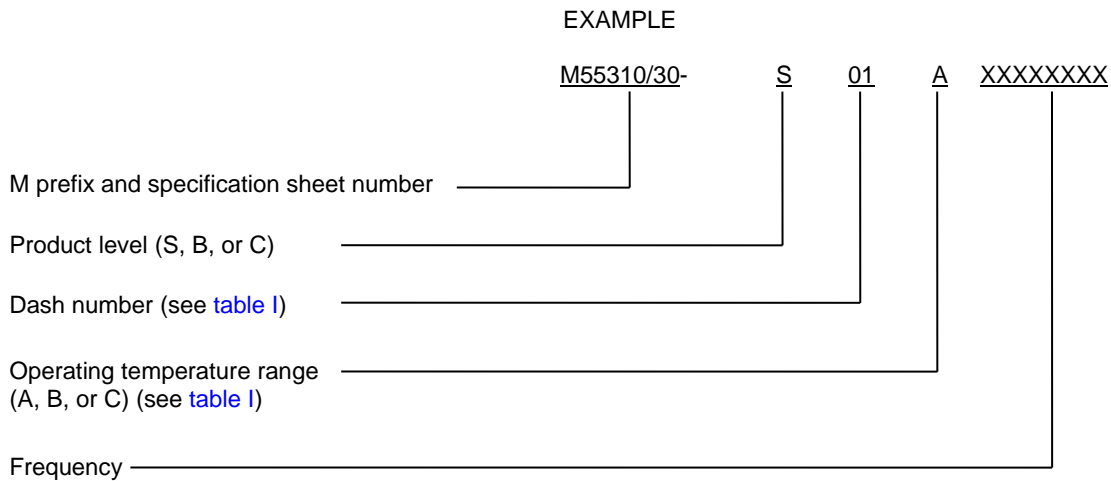

Reference documents. In addition to [MIL-PRF-55310](#), this document references the following:
[MIL-STD-202-105](#) [MIL-STD-202-204](#) [MIL-STD-202-211](#)

The margins of this specification are marked with vertical lines to indicate where changes from the previous issue were made. This was done as a convenience only and the Government assumes no liability whatsoever for any inaccuracies in these notations. Bidders and contractors are cautioned to evaluate the requirements of this document based on the entire content irrespective of the marginal notations and relationship to the last previous issue.

Custodians:
Army - CR
Navy - EC
Air Force - 184
DLA - CC

Preparing activity:
Army - CR

Agent:
DLA - CC

Review activities:
Army - AR, MI, SM
Navy - AS, CG, MC
Air Force - 71
NASA - NA

(Project 5955-2018-004)

NOTE: The activities listed above were interested in this document as of the date of this document. Since organizations and responsibilities can change, you should verify the currency of the information above using the ASSIST Online database at <https://assist.dla.mil>.