



"XD35T" LVDS Series – (New Space Applications)

3.2 x 5.0mm, Hi-Rel Hybrid Microcircuit Crystal Oscillators

3.3V & 2.5V LVDS

50 MHz to 200 MHz

Features

- 50K Rads(Si) Min.Total Dose Ionization
- Latch-up Immune up to 85 MeV cm²/mg LET
- Crystal Mounted at 3 Points
- High Shock & Vibration Design
- Tristate Enable/Disable function is included by default
- Low Profile Surface Mount, 0.065" Max. Height
- 100% Screening per MIL-PRF-55310, Level B plus PIND
- Low Phase Noise
- Hermetically Sealed, Ceramic Package
- Tape & Reel packaging
- Made in USA, ECCN: EAR99

Applications

- New Space, LEO
- Micro & Nano Satellites
- Commercial Satellites

Package Specifications & Outline:

- Package: Ceramic 90% Al₂O₃
- Seal: Hermetic – Resistance Welded
- Weight: 0.06g typical, 0.07g Max.

- Solder Reflow, Temp./Time: 260 °C Max for 10 Seconds Max.

- Pad Finish: 1.27 to 1.9 μm gold over 2.0 to 3.5 μm nickel

Hot Solder Tinning per MIL-PRF-55310 is optional at additional cost.

Contact Xsis Electronics at xisis@xisis.com for any special requirements.

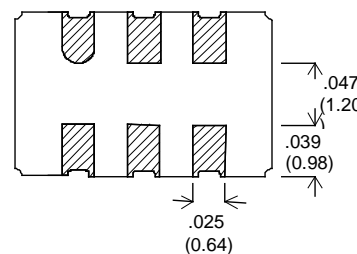
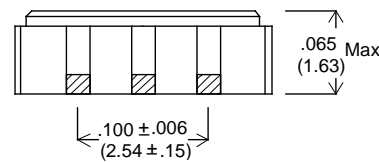
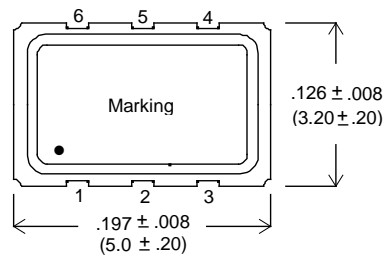

PAD#	FUNCTION
1	ENABLE/DISABLE
2	N/C
3	GND/CASE
4	COMP. OUTPUT
5	OUTPUT
6	VDD

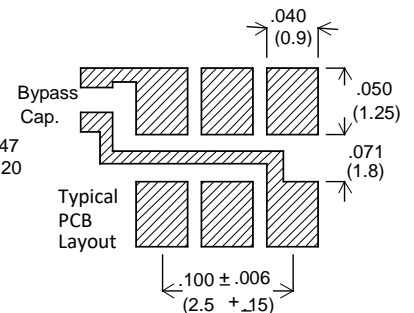

Dimensions: Inches (mm).

An External 0.01uF Bypass Capacitor is recommended between VDD and GND.

Tristate Input: A "Low" level at the input disables the Output into a high impedance state.

Tristate Input has internal pull-up. It can be left floating or connected to Vdd.

ORDERING INFORMATION (Please build your part number from options below) :

P/N EXAMPLE: XD35T - L7M - 125.000 MHz = 3.3V LVDS, ± 75 PPM Overall Frequency Accuracy over -55 °C to +125 °C, Tristate Output, 100% Screening, 125.000 MHz

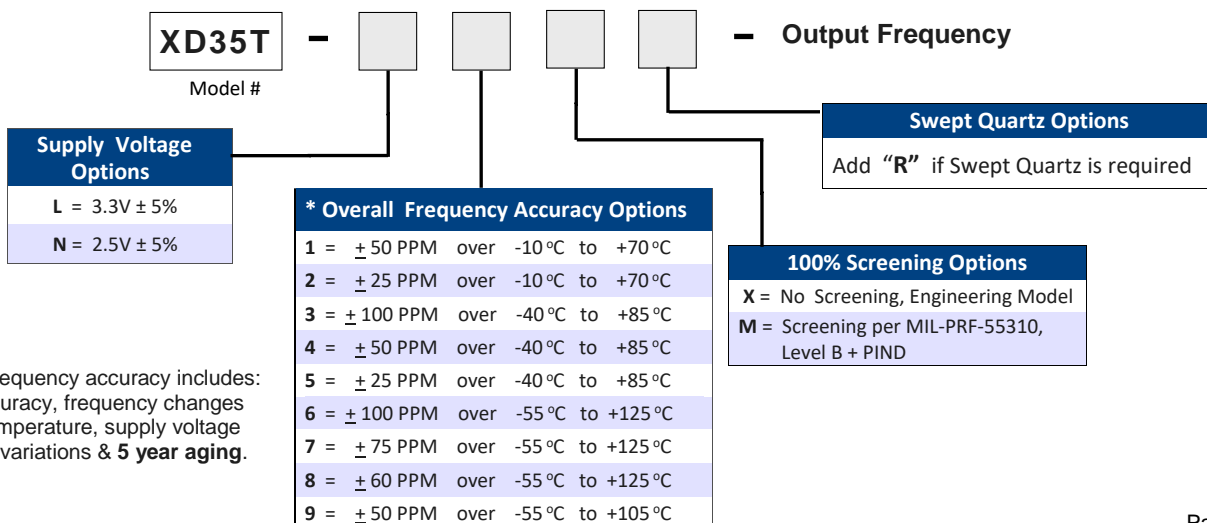

* Overall frequency accuracy includes: initial accuracy, frequency changes due to temperature, supply voltage and load variations & 5 year aging.



"XD35T" LVDS Series – (New Space Applications)

3.2 x 5.0mm, Hi-Rel Hybrid Microcircuit Crystal Oscillators

3.3V & 2.5V LVDS

50 MHz to 200 MHz

Table I - Electrical Specifications for 2.5V & 3.3V:

Parameter	Specification Limits
Output Frequency Range	50 MHz - 200 MHz
Overall Frequency Accuracy	See Options in the Ordering Information on Page 1
Operating Temperature Range	See Options in the Ordering Information on Page 1
Supply Voltage (Vdd)	See Options in the Ordering Information on Page 1
Input Current (no Load)	35 mA Max.
Output Waveform	Square Wave, LVDS Compatible
Output Duty Cycle - HCMOS (at 50% Level)	45/55%
Output Load	100 Ω across outputs
Output High Level	1.45 VDC Typical, 1.6 VDC Max.
Output Low Level	1.10 VDC Typical, 0.9 VDC Min.
Differential Output Voltage (Peak to Peak)	340 mV Typical, 247 mV Min., 454 mV Max.
Offset Voltage	1.25 VDC Typical, 1.125 VDC Min., 1.375 VDC Max.
Offset Error	50 mV Max.
Output Current	3.5 mA Typical
Rise & Fall Times (Typical Load)	600 pS Max. (20% to 80% of Output Levels)
Tristate Input	≥ 0.7 Vdd or Open : Normal Output ≤ 0.3 Vdd: High Impedance
Start-Up Time	10 mS Max.
Phase Jitter (10 KHz - 20 MHz Integrated)	0.5 pS rms Typical
Aging at 70 °C	± 5 PPM Max. first year, ± 2 PPM Max. per year thereafter
Absolute Maximum Applied Voltage	+ 4.5 VDC
Storage Temperature	-65 °C to +125 °C

NOTE: Overall Frequency Accuracy Includes, Initial Accuracy at 25 °C, Frequency changes over Operating Temperature, Frequency changes due to Supply Voltage & Load Variations & Aging over 5 years.

For any special requirements, Contact Xsis Electronics at xisis@xisis.com or call us at 913-631-0448.



“XD35T” LVDS Series – (New Space Applications)

3.2 x 5.0mm, Hi-Rel Hybrid Microcircuit Crystal Oscillators

3.3V & 2.5V LVDS

50 MHz to 200 MHz

Table II - 100% Screening per MIL-PRF-55310, Level B + PIND

Test - Inspection	Test Method – Condition
Internal Visual	MIL-STD-883, Method 2017, Level B
Stabilization Bake (Prior to Seal) <u>1/</u>	MIL-STD-883, Method 1008, Condition C, (+150 °C), 24 hours minimum
Temperature Cycling	MIL-STD-883, Method 1010, Condition B
Constant Acceleration	MIL-STD-883, Method 2001, Condition A, Y ₁ axis only (5000 G)
Seal (Fine and Gross Leak)	MIL-PRF-55310, Para. 4.8.2.2.2 (1(10) ⁻⁸ atm-cc/s Max.)
Particle Impact Noise Detection (PIND)	MIL-STD-883, Method 2020, Condition A
Pre Burn-in Electrical Tests: Record as applicable	Refer to Table III-a below
Burn-in	+125 °C, Nominal Supply Voltage and Burn-in load, 160 Hours Minimum
Post Burn-in Electrical Tests: Record as applicable	Refer to Table III-a below
External Visual	MIL-STD-883, Method 2009

1/ Vacuum bake and maintain oscillators in dry nitrogen per MIL-PRF-55310

Table II-a – Pre & Post Burn-in Electrical Tests

Test Parameter	MIL-PRF-55310 Method	Pre BI 24 ± 1 °C	Post BI 24 ± 1 °C	Post BI Low Temp	Post BI High Temp
Input Current	4.8.5	✓	✓	✓	✓
Output Frequency	4.8.6	✓	✓	✓	✓
Frequency Vs. Temperature Stability	4.8.10.1		✓	✓	✓
Frequency Vs. Supply Voltage	4.8.14		✓	✓	✓
Output Voltage Levels	4.8.21.3	✓	✓	✓	✓
Output Rise & Fall Times	4.8.22	✓	✓	✓	✓
Output Duty Cycle	4.8.23	✓	✓	✓	✓
Start-up time	4.8.29		✓	✓	✓
Enable/Disable, if applicable	4.8.28		✓	✓	✓

Quality Conformance Inspection: Group A per MIL-PRF-55310, Level B

The following QCI options are available at additional cost:

Non-destruct Bond Pull per MIL-STD-883, Method 2023

Radiographic Inspection per MIL-STD-883, Method 2012, Class S

DPA (Destructive Physical Analysis) per Customer Specified Method.

Life Test per MIL-STD-883, Method 105, 1000 Hrs. at +125 °C



“XD35T” LVDS Series – (New Space Applications)

3.2 x 5.0mm, Hi-Rel Hybrid Microcircuit Crystal Oscillators

3.3V & 2.5V LVDS

50 MHz to 200 MHz

Packaging: Tape & Reel, See Page 6

Table III - Typical Phase Noise (dbc/Hz):

Output Frequency	10 Hz	100 Hz	1 KHz	10 KHz	100 KHz	1 MHz
80 MHz	-73	-101	-131	-146	-151	-154
125 MHz	-71	-98	-129	-145	-149	-153
160 MHz	-69	-96	-128	-144	-147	-150
200 MHz	-67	-96	-127	-143	-147	-150

Table IV - Environmental Specifications:

XD35T series oscillators are designed to meet or exceed the Environmental tests specified below. Customized screening and environmental testing are also available to meet your special requirements.

Test	Test Conditions
Vibration	0.06" DA, 30 G peak, 10 - 2000 Hz, MIL-STD-202, Method 204, Cond. G
Shock	5000 G, 0.5 mS, half-Sine, MIL-STD-883, Method 2002, Cond. B modified
Temperature Cycling	MIL-STD-883, Method 1010, Cond. C
Thermal Shock	MIL-STD-202, Method 107, Cond. B
Seal (Fine and Gross)	MIL-STD-883, Method 1014 Cond. A & C
Burn-in	160 Hours, 125 °C, Nominal Supply Voltage & Load
Frequency Aging	± 1.5 PPM Max. first 30 days, ± 3 PPM Max. first year, ± 2 PPM Max. per year thereafter
Altitude	MIL-STD-202, Method 105, Cond. C
Constant Acceleration	MIL-STD-883, Method 2001, 5000 G
Moisture Resistance	MIL-STD-202, Method 106, Vibration Sub Cycle Omitted
Solderability	MIL-STD-202, Method 208
Resistance to Soldering Heat	MIL-STD-202, Method 210, Cond B. or C as applicable
Resistance to Solvents	MIL-STD-202, Method 215
Internal Water Vapor Content	MIL-STD-883, Method 1018
ESD Classification	MIL-STD-883, Method 3015, Class 1C, HBM 1000 to 1999
Moisture Sensitivity Level	J-STD-020, MSL=1



"XD35T" LVDS Series – (New Space Applications)

3.2 x 5.0mm, Hi-Rel Hybrid Microcircuit Crystal Oscillators

3.3V & 2.5V LVDS

50 MHz to 200 MHz

LVDS Test Circuit

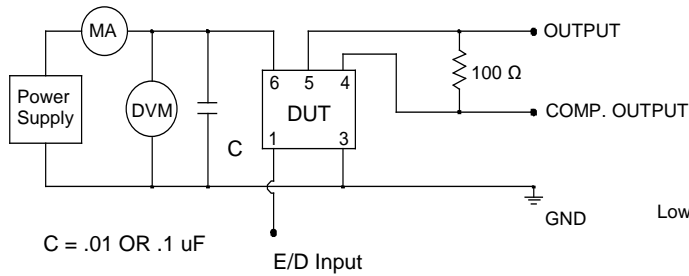

Tristate Input has an internal pull-up resistor. It can be left floating or connected

LVDS Output Waveform

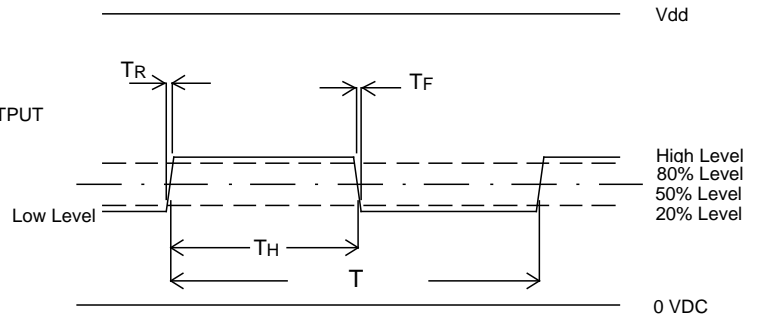

$$\text{Symmetry} = \frac{T_H}{T} \times 100\%$$

Typical Freq. Stability Vs. Temperature

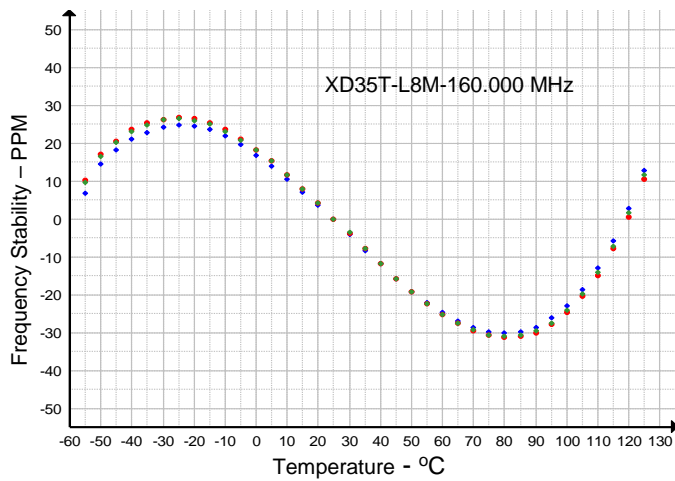

Tape & Reel Information

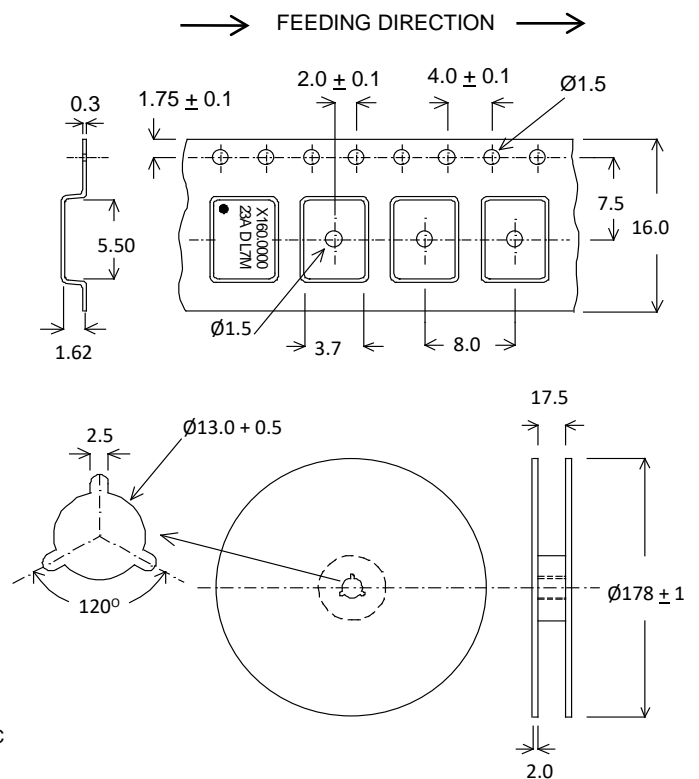

Dimensions are in mm.

Typical Solder Reflow Profile

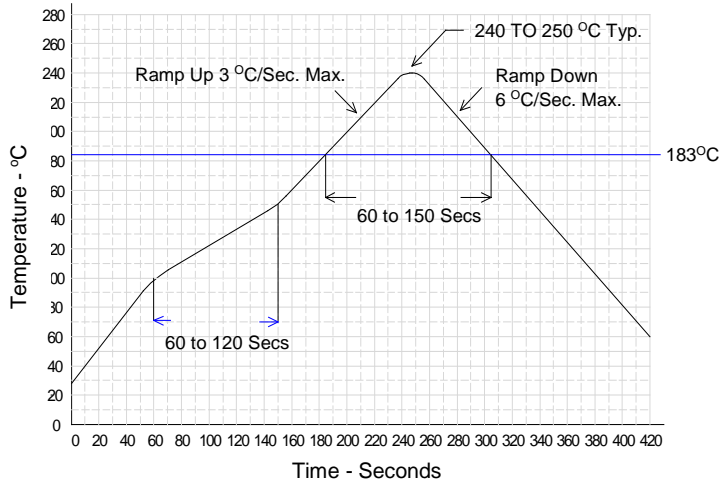

Tape is EIA-481-A Compliant.