

REV LTR	DESCRIPTION	DATE	APPVD.
-	Orig. Release	10/15/22	MLG

**XD83N SERIES**

**( XD83N-Nx, XD83N-Lx**

**LVDS OSCILLATORS**

**FOR SPACE & HI-REL APPLICATIONS**

**75 MHz to 200 MHz**

**( 5 x 7 mm, Through-Hole, 2.5V, 3.3V & 5.0V )**

**QCI & SCREENING PER EEE-INST-002**

**( Refer to Page 5 for Reduced QCI Models XD83E, XD83B & XD83P )**

REV STATUS OF SHEETS	REV																
	SHEET NO.	1	2	3	4	5	6	7	8	9	10	11	12	13	14	15	16
APPROVALS	DATE	XSIS ELECTRONICS, INC.															
PREP. S. Gupta	10/15/22	12620 W. 63 <sup>rd</sup> Street, Shawnee, KS 66216 USA															
ENG. M. Gupta	10/15/22	<b>XD83N SERIES LVDS OSCILLATORS</b>															
Q. A. M. Gupta	10/15/22																
CUST. ENG.		FSC NO. 57051						DWG. NO. XD83N									
CUST Q A.		SCALE N/A						SHEET 1 OF 10									

1. SCOPE:

XD8N, LVDS series, high reliability hybrid microcircuit crystal oscillators are designed, produced and tested by Xsis Electronics, Inc. as MIL-PRF-55310, Class "S" equivalent devices for use in advanced industrial, military, avionics and space applications. These devices are of hybrid microcircuit technology conforming to MIL-PRF-55310, Type 1, Class 2 oscillators.

100% Screening and QCI are performed per **EEE-INST-002**.

- 1.1 ALTERNATE MODELS: Alternate models, **XD83E, XD83B and XD83P** with reduced QCI and/or reduced screening and shorter lead times are also offered as explained on page 5.

2. APPLICABLE DOCUMENTS:

MIL-PRF-55310F	Oscillator, Crystal Controlled, General Specifications for
MIL-PRF-38534K	Hybrid Microcircuits, General Specifications for
MIL-STD-883L	Test Methods and Procedures for Microelectronics
EEE-INST-002	Instructions for EEE Parts Selection, Screening, Qualification and Derating

3. REQUIREMENTS:

- 3.1 General: The individual item requirements shall be as specified herein.

- 3.2 Package: Ceramic, 90% Min. AL<sub>2</sub>O<sub>3</sub>. Weight 0.4 g Max., Thermal Resistance,  $\theta_{JC}$ : 50 °C / Watt.

- 3.2.1 Lead Material & finish: Kovar, 50 to 85 micro-inches gold over 100 to 250 micro-inches nickel. Hot Solder tinning with Sn63/Pb37 solder per MIL-PRF-55310 is optional at an additional cost.

- 3.2.2 Reflow Soldering: Reflow soldering at 260 °C for 10 seconds shall not degrade the performance.

- 3.3 Hermeticity: Resistance welded, hermetically sealed, leak rate of 1(10)<sup>-8</sup> atm-cc/s Max.

- 3.4 Marking: As a minimum, the parts shall be marked with Xsis P/N, ESD symbol, date code and serial number.

- 3.5 Absolute Maximum Ratings: Unless otherwise specified, absolute maximum ratings shall be as follows:

Supply Voltage	-0.5 to +4.5 VDC
Operating Free-Air Temperature Range	-55°C to +125°C
Storage Temperature	-55°C to +125°C

- 3.6 Electrical Characteristics: See Table I

- 3.6.1 Total Dose Radiation: The Hybrid Microcircuit Crystal Oscillators shall be capable of meeting the electrical characteristics of Para. 3.6 after being exposed to total ionizing dose radiation of 100 krad as per MIL-STD-883, method 1019.

- 3.7 Hybrid Elements:

- 3.7.1 Quartz Crystals: A high-grade cultured quartz crystal shall be used. As an option, Xsis will use premium Q swept quartz crystal at an additional charge, refer to part numbering example in paragraph 6 to specify swept quartz crystal. Crystal element evaluation shall be in accordance with MIL-PRF-55310.

- 3.7.2 Crystal Mounting: The Crystal element shall be mounted at 4 points in such a manner as to provide adequate ruggedness and performance under extreme environments specified herein.

- 3.7.3 Passive Elements: Established Reliability (ER) QPL components, failure level R minimum shall be used or element lot evaluation shall be as per MIL-PRF-55310, class S, or MIL-PRF-38534, Appendix C, Class K as applicable.

**XSIS ELECTRONICS, INC.**

**12620 W. 63<sup>rd</sup> St., Shawnee, KS 66216 USA**

Tel: 913-631-0448 e-mail: xsis@xis.com website: www.xsis.com

**FSC NO.**

**57051**

**DWG. NO.**

**XD83N**

**REV**

**SCALE**

**N/A**

**SHEET**

**2 OF 10**

- 3.7.4 The microcircuit die shall be from lots that have passed the element evaluation per MIL-PRF-38534, Level K. In addition, ionizing radiation testing shall be performed at the oscillator level as explained in paragraph 3.7.5 herein.
- 3.7.5 The Microcircuit die shall be from wafer lots that have been successfully tested in the oscillator for ionizing radiation up to 100 krad. Xsis Electronics has also performed SET & SEL on the microcircuit die. The die is SEL immune for LET of up to 95 Mev-cm<sup>2</sup>/mg. Test reports are available on request.
- 3.7.6 Workmanship: Assembly, Rework and Process controls shall be in accordance with the requirements of MIL-PRF-55310 & MIL-PRF-38534 as applicable.
- 3.7.7 Lot Traceability: Production lot for these oscillators shall be homogenous. Each element used in the production lot shall be traceable to a single lot. Swept quartz shall be traceable to the quartz bar, and its applicable processing details.
- 3.7.8 Prohibited Materials: The following items shall not be used in these oscillators: Pure Tin (Sn >97%), Cadmium, Zinc, Mercury, Selenium, Silver as under plate, and Gold Plating without a nickel barrier.
- 3.7.9 Element Derating: All active and passive elements shall be derated in accordance with the applicable Hybrid microcircuit requirements of MIL-STD-975. Elements shall not operate in excess of derated values.
- 3.7.10 Material Outgassing: All materials shall meet a TML of 1% Max. and a CVCM of 0.1% Max., when tested in accordance with ASTM E595.

4. QUALITY ASSURANCE PROVISIONS: The quality assurance provisions shall be as specified herein.

- 4.1 100% Screening: The 100% screening shall be performed in accordance with EEE-INST-002 and as specified in Table II. In addition, MIL-PRF-38534 Group B Option 1 in-line inspection for bond strength and die shear shall be performed at pre-seal inspection. PDA requirements for nondestructive bond pull, burn-in and frequency aging shall be as specified below.
- 4.2 PDA for Non-destruct Bond Pull: Unless otherwise specified, PDA shall be 2% of total number of wires or 1 wire whichever is greater.
- 4.3 PDA for Burn-in and Frequency Aging Failures: Unless otherwise specified, PDA for burn-in failures, applicable to +23 °C and/or +25 °C static tests only, and frequency aging failures combined shall be 5% or 1 part whichever is greater. In addition, delta calculations for input current shall be performed after burn-in at the specified nominal supply voltage. All parts that exceed the specified limits below shall be rejected and be counted for PDA.

Input Current	10% change Maximum
Frequency Aging/30 days	Refer to the specified limit in Table I

- 4.4 Qualification Inspection: Devices shall be capable of meeting the qualification inspection shown in Table III. When required by the purchase order, qualification inspection shall be performed as per Table III on sample units selected from the units that have successfully passed 100% screening specified herein. Number of sample units shall be as specified in Table III. With customer approval, generic qualification inspection data on similar parts may be used to satisfy this requirement, except for Subgroup 5 which needs to be performed on a lot specific basis unless otherwise specified by the customer.
- 4.5 DPA: When required by the purchase order, Destructive physical analysis as per GFSC S-311-M-70 shall be performed on a number of sample units as required by the purchase order by a laboratory approved by the customer.

<b>XSIS ELECTRONICS, INC.</b> 12620 W. 63 <sup>rd</sup> St., Shawnee, KS 66216 USA Tel: 913-631-0448 e-mail: xsis@xis.com website: www.xsis.com	FSC NO. <b>57051</b>	DWG. NO. <b>XD83N</b>	REV
	SCALE    N/A	SHEET    3 OF 10	

4.6 Inspection and Test Data: Unless otherwise specified in the purchase order, the following Inspection and test data documentation shall be supplied with the parts.

( See Page 5 for the description of the alternate Model Numbers XD83E, XD83B, & XD83P )

**Model XD83N:**

Certificate of Conformance  
Summary of 100% Screening Test Results  
PDA Calculations for Non-Destruct Bond Pull, Burn-in and Frequency Aging  
Summary of Elements Lot Traceability  
Electrical Tests data taken during 100% screening  
Radiographic Inspection Certificate  
Qualification data if required by the purchase order  
DPA report if required by the purchase order  
Qualification and DPA test samples as applicable

**Model XD83E:**

Certificate of Conformance  
Summary of Screening Test Results per Table IV  
Summary of Elements Lot Traceability  
Group A Inspection Summary  
Radiographic Inspection Certificate

**Model XD83B:**

Certificate of Conformance  
Summary of Screening Test Results per Table IV  
Group A Inspection Summary  
Radiographic Inspection Certificate, if required by the Purchase Order

**Model XD83P:**

Certificate of Conformance

4.7 The following test and inspection options are available at customer request.

Customer Source Inspection for Pre-Cap and Final  
DPA (Destructive Physical Analysis)  
Qualification Inspection per Table III

5. PRESERVATION, PACKAGING AND PACKING: The oscillators shall be clean, dry and packaged in a manner to provide adequate protection against electrostatic discharge, corrosion, deterioration and physical damage during shipment.

<b>XSIS ELECTRONICS, INC.</b> 12620 W. 63 <sup>rd</sup> St., Shawnee, KS 66216 USA Tel: 913-631-0448 e-mail: xsis@xis.com website: www.xsis.com	<b>FSC NO.</b> 57051	<b>DWG. NO.</b> XD83N	<b>REV</b>
	<b>SCALE</b> N/A	<b>SHEET</b> 4 OF 10	

6. PART NUMBERING EXAMPLE:

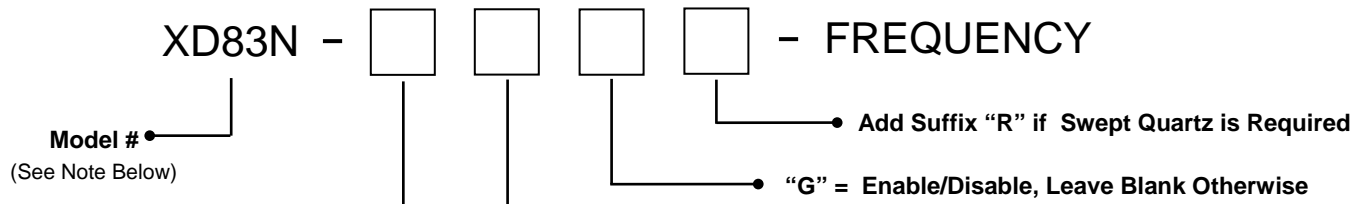

**Supply Voltage**  
**L = 3.3 V ± 5%**  
**N = 2.5 V ± 5%**

**\* Overall Frequency Accuracy Options**

- 1 = ± 50 PPM -10 °C to +70 °C
- 2 = ± 25 PPM -10 °C to +70 °C
- 3 = ± 100 PPM -40 °C to +85 °C
- 4 = ± 50 PPM -40 °C to +85 °C
- 5 = ± 25 PPM -40 °C to +85 °C
- 6 = ± 100 PPM -55 °C to +125 °C
- 7 = ± 75 PPM -55 °C to +125 °C
- 8 = ± 60 PPM -55 °C to +125 °C

\* Overall Frequency Accuracy includes effects of Operating Temperature, Supply Voltage, Load variations and **5 year aging**

**P/N Example: XD83N- L8 -100.000 MHz = 100.000 MHz, 3.3V Oscillator, ± 60 PPM Overall Frequency Accuracy over operating temperature range of -55 °C to +125 °C,**

**NOTE:** Besides model XD83N above, the following additional models are available for applications that can accommodate reduced level of Elements, Screening and Quality Conformance inspection:

**XD83E: Model XD83E** uses the same design and elements as **Model XD83N** except as follows:

- 100% screening is as per Table IV herein
- PDA for Burn-in is 10% or 1 unit whichever is greater
- Delta measurements of paragraph 4.3 are not applicable
- Group A inspection is as per MIL-PRF-55310, Class B

**XD83B: Model XD83B** is same as **Model XD83E** except as follows:

- Active and Passive Elements are as per MIL-PRF-38534, Class H. Microcircuit die is similar to the one used in Model XD83N but is not from radiation tested wafer lot.
- Radiographic Inspection is not applicable.

**XD83P: Model XD83P** is a form, fit and function equivalent prototype of **Model XD83N**.

- Prototypes may use commercial grade elements. 100% screening and quality conformance inspection are not applicable.

<b>XSIS ELECTRONICS, INC.</b> 12620 W. 63 <sup>rd</sup> St., Shawnee, KS 66216 USA Tel: 913-631-0448 e-mail: xsis@xis.com website: www.xsis.com	<b>FSC NO.</b> 57051	<b>DWG. NO.</b> XD83N	<b>REV</b>
	<b>SCALE</b> N/A	<b>SHEET</b> 5 OF 10	

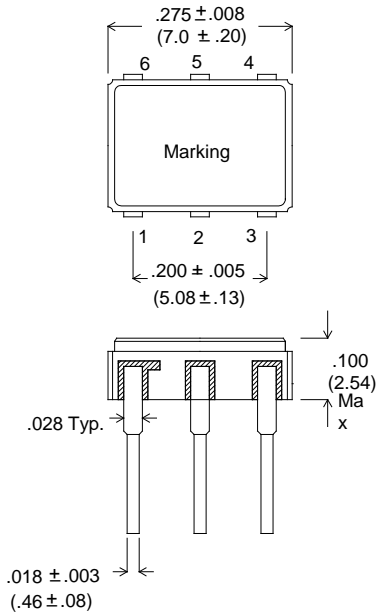

Dimensions are in inches (mm)

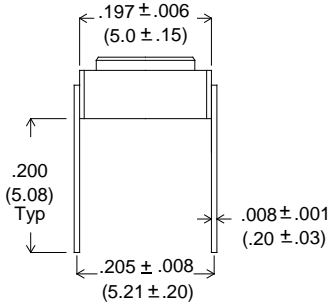

LEAD#	FUNCTION
1	E/D (Optional)
2	N/C
3	GND/CASE
4	COMP. OUTPUT
5	OUTPUT
6	VDD

**Enable/Disable Input:** A "Low" level at the input disables the Output into a high impedance state. Enable/Disable Input has internal pull-up.

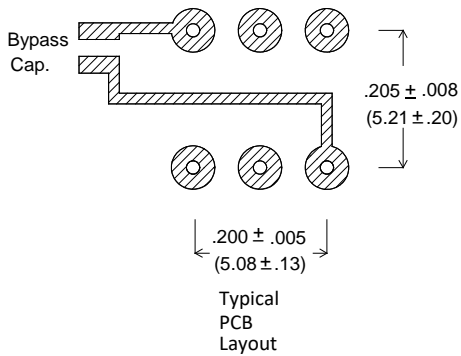

**An External 0.01uF Bypass Capacitor is required between VDD and GND.**

Figure 1 - Package Configuration & Pin Connections

TABLE I – Electrical Characteristics for 2.5 V & 3.3V

Parameter	Spec. Limits
Frequency Range	75 MHz to 200 MHz
Overall Frequency Accuracy <sup>1/</sup>	See Options in Paragraph 6.0
Operating Temperature Range	See Options in Paragraph 6.0
Supply Voltage	See Options in Paragraph 6.0
Input Current ( no load )	65 mA Max.
Output Waveform	Square Wave
Output Duty Cycle	55/45% Max
Output Load	100 ohm across outputs
High Output Level	1.45V typical, 1.60 V Max.
Low Output Level	1.10V typical, 0.90 V Min.
Differential Output Voltage (Peak to Peak)	340 mV typical, 247 mV Min., 454 mV Max.
Offset Voltage	1.25 V typical, 1.125 V Min., 1.375 V Max.
Offset Error	50 mV Max.
Rise & Fall Times ( 20% to 80% Levels )	600 pS Max. over -55 °C to +105 °C 700 pS Max. over +105 °C to +125 °C
Enable/Disable ( E/D ) Input	≥ 0.7 V <sub>dd</sub> or Open: Normal Output ≤ 0.3 V <sub>dd</sub> : High Impedance
Start-up Time	10 mS Max.
Phase Jitter	0.3 pS rms typ, (10 KHz to 20 MHz Integrated )
Frequency Aging @ 70 °C ≤ 150 MHz  > 150 MHz	± 1.5 PPM Max./30 days 5 PPM Max. first year, 2 PPM Max/year thereafter  ± 2.0 PPM Max./30 days 6 PPM Max. first year, 2.5 PPM Max/year thereafter

Contact Xsis Engineering for any other special requirements.

<sup>1/</sup> Overall Frequency Accuracy includes effects of operating temperature, ± 5% Supply Voltage and ± 10% load variations and 5 year aging.

<b>XSIS ELECTRONICS, INC.</b> 12620 W. 63 <sup>rd</sup> St., Shawnee, KS 66216 USA Tel: 913-631-0448 e-mail: xsis@xsis.com website: www.xsis.com	<b>FSC NO.</b> 57051	<b>DWG. NO.</b> XD83N	<b>REV</b>
	<b>SCALE</b> N/A	<b>SHEET</b> 7 OF 10	

**Table II - Model XD83N, Screening (100%)**

Test - Inspection	Test Method – Condition
Nondestructive Bond Pull	MIL-STD-883, Method 2023
Internal Visual	MIL-STD-883, Method 2017, Level S
Stabilization Bake ( Prior to Seal ) <sup>1/</sup>	MIL-STD-883, Method 1008, Condition C ( +150 °C ), 48 hours minimum
Thermal Shock	MIL-STD-883, Method 1011, Condition A
Temperature Cycling	MIL-STD-883, Method 1010, Condition C
Constant Acceleration	MIL-STD-883, Method 2001, Condition A Y <sub>1</sub> axis only ( 5000 G )
Seal ( Fine and Gross Leak )	MIL-STD-883, Method 1014, Cond. A or B for Fine Leak & Cond. C for Gross Leak
Particle Impact Noise Detection ( PIND )	MIL-STD-883, Method 2020, Condition A
Radiographic Inspection Radiographic Inspection	MIL-STD-883, Method 2012, Class S
Pre Burn-in Electrical Tests: Record as applicable	Refer to Table II-a below
Burn-in	+125 °C, Nominal Supply Voltage and Burn-in load, 320 Hours Minimum
Post Burn-in Electrical Tests: Record as applicable	Refer to Table II-a below
Frequency Aging	MIL-PRF-55310, Para. 4.8.35
PDA Calculation	5% PDA (combined Burn-in & Frequency Aging rejects )
Additional Electrical Measurements	Refer to Table II-b
External Visual	MIL-STD-883, Method 2009

<sup>1/</sup> Vacuum bake and maintain oscillators in dry nitrogen per MIL-PRF-55310.

**Table II-a - Pre, Interim & Post Burn-in Electrical Tests**

Test Parameter	MIL-PRF-55310 Method	Pre BI 24 ± 1 °C	Interim BI 24 ± 1 °C	Post BI 24 ± 1 °C	Post BI Low Temp	Post BI High Temp
Input Current	4.8.5	✓	✓	✓	✓	✓
Output Frequency	4.8.6	✓	✓	✓	✓	✓
Frequency Vs. Temperature Stability	4.8.10.1	✓	✓	✓	✓	✓
Frequency Vs. Supply Voltage	4.8.14	✓	✓	✓	✓	✓
Output Voltage Levels	4.8.21.3	✓	✓	✓	✓	✓
Output Rise & Fall Times	4.8.22	✓	✓	✓	✓	✓
Output Duty Cycle	4.8.23	✓	✓	✓	✓	✓
Start-up time	4.8.29	✓	✓	✓	✓	✓
Enable/Disable, if applicable	4.8.28	✓	✓	✓	✓	✓

<b>XSIS ELECTRONICS, INC.</b> 12620 W. 63 <sup>rd</sup> St., Shawnee, KS 66216 USA Tel: 913-631-0448 e-mail: xsis@xis.com website: www.xsis.com	<b>FSC NO.</b> 57051	<b>DWG. NO.</b> XD83N	<b>REV</b>
	<b>SCALE</b> N/A	<b>SHEET</b> 8 OF 10	



Table II-b - Additional Electrical Measurements

Test Parameter	MIL-PRF-55310 Method	24 ± 1 °C	Low Temp	High Temp
Input Current	4.8.5	✓	✓	✓
Output Frequency	4.8.6	✓	✓	✓
Frequency Vs. Temperature Stability	4.8.10.1	Measure the output frequency at a minimum of 11 equispaced points over the specified operating temperature range.		
Frequency Vs. Supply Voltage	4.8.14	✓	✓	✓
Output Voltage Levels	4.8.21.3	✓	✓	✓
Output Rise & Fall Times	4.8.22	✓	✓	✓
Output Duty Cycle	4.8.23	✓	✓	✓
Start-up time	4.8.29	✓	✓	✓
Enable/Disable, if applicable	4.8.28	✓	✓	✓
Supply Voltage		✓		
Overvoltage Survivability		✓		

Table III - Qualification Inspection 3/

Test / Inspection	Test Methods	Qty
Group 1 <u>1/</u> Frequency Aging	MIL-PRF-55310, Para. 4.8.35	8(0)
Group 2 <u>2/</u> Vibration (Sinusoidal, non-operating) Shock ( Non-operating )	MIL-STD-202, Method 204, Cond. G and MIL-PRF-55310, Para. 4.8.39.1 MIL-STD-202, Method 213, Cond. G and MIL-PRF-55310, Para. 4.8.41	8(0)
Group 3 <u>2/</u> Thermal Shock	MIL-STD-202, Method 107 and MIL-PRF-55310, Para. 4.8.45	4(0)
Group 4 <u>2/</u> Resistance to Soldering Heat Moisture Resistance Terminal Strength Solderability Resistance to Solvents	MIL-STD-202, Method 210 and MIL-PRF-55310, Para. 4.8.49 MIL-STD-202, Method 106 and MIL-PRF-55310, Para. 4.8.50 MIL-STD-883, Method 2004, Cond. D and MIL-PRF-55310, Para. 4.8.52 MIL-STD-202, Method 208, each pad MIL-STD-202, Method 215	2(0)
Group 5 Internal Water Vapor Content	MIL-STD-883, Method 1018, 5000 PPM at 100 °C	5(1) or 3(0)

1/ Aging Data from Screening may be used in lieu of testing.

2/ Samples for this Subgroup come from Group 1 samples.

3/ Generic data less than 1 year old is acceptable as a basis for qualification if it satisfies the requirements specified herein, however, Subgroup 5 must be performed on a lot specific basis.

<b>XSIS ELECTRONICS, INC.</b> 12620 W. 63 <sup>rd</sup> St., Shawnee, KS 66216 USA Tel: 913-631-0448 e-mail: xsis@xis.com website: www.xsis.com	<b>FSC NO.</b> 57051	<b>DWG. NO.</b> XD83N	<b>REV</b>
	<b>SCALE</b> N/A	<b>SHEET</b> 9 OF 10	

Table IV - Models XD83E & XD83B, Screening (100%)

Test - Inspection	Test Method – Condition
Nondestructive Bond Pull	MIL-STD-883, Method 2023
Internal Visual	MIL-STD-883, Method 2017, Level B
Stabilization Bake ( Prior to Seal ) <u>1/</u>	MIL-STD-883, Method 1008, Condition C ( +150 °C ), 24 hours minimum
Temperature Cycling	MIL-STD-883, Method 1010, Condition B
Constant Acceleration	MIL-STD-883, Method 2001, Condition A Y1 axis only ( 5000 G )
Seal ( Fine & Gross )	MIL-PRF-55310, Para. 4.8.2.2.2
Particle Impact Noise Detection ( PIND )	MIL-STD-883, Method 2020, Condition A
Radiographic Inspection ( Model XD83E only ) <u>2/</u>	MIL-STD-883, Method 2012, Class S
Pre Burn-in Electrical Tests	Refer to Table IV-a below
Burn-in	+125 °C, Nominal Supply Voltage and Burn-in load, 160 Hours Minimum
Post Burn-in Electrical Tests	Refer to Table VII-a below
External Visual	MIL-STD-883, Method 2009

1/ Vacuum bake and maintain oscillators in dry nitrogen per MIL-PRF-55310.

2/ Radiographic Inspection is applicable to Model XD83E only

Table IV-a – Pre & Post Burn-in Electrical Tests

Test Parameter	MIL-PRF-55310 Method	Pre BI 24 ± 1 °C	Post BI 24 ± 1 °C	Post BI Low Temp	Post BI High Temp
Input Current	4.8.5	✓	✓	✓	✓
Output Frequency at 23 to 25 °C	4.8.6	✓	✓	✓	✓
Frequency Vs. Temperature Stability	4.8.10.1	✓	✓	✓	✓
Frequency Vs. Supply Voltage	4.8.14	✓	✓	✓	✓
Output Voltage Levels	4.8.21.3	✓	✓	✓	✓
Output Rise & Fall Times	4.8.22	✓	✓	✓	✓
Output Duty Cycle	4.8.23	✓	✓	✓	✓
Start-up time	4.8.29	✓	✓	✓	✓
Enable/Disable, if applicable	4.8.28	✓	✓	✓	✓

<b>XSIS ELECTRONICS, INC.</b> 12620 W. 63 <sup>rd</sup> St., Shawnee, KS 66216 USA Tel: 913-631-0448 e-mail: xsis@xis.com website: www.xsis.com	<b>FSC NO.</b> 57051	<b>DWG. NO.</b> XD83N	<b>REV</b>
	<b>SCALE</b> N/A	<b>SHEET</b> 10 OF 10	