

REV LTR	DESCRIPTION	DATE	APPVD.
-	Orig.	6/18/13	MLG
A	Updated per 2016-7	12/15/16	SPG

**XSIS XE61S-N00 SERIES**  
**HC/ACMOS OSCILLATORS**  
**FOR SPACE APPLICATIONS**  
  
**125 Hz to 120 MHz**  
  
**( 4 PIN DIP, 2.5 V )**

( Refer to Page 5 for Models with Reduced Screening & QCI )

REV STATUS OF SHEETS	REV SHEET NO.	1	2	3	4	5	6	7	8	9	10	11	12	13	14	15	16
APPROVALS	DATE	XSIS ELECTRONICS, INC.															
PREP. S. Gupta	6/18/13	12620 W. 63 <sup>rd</sup> Street, Shawnee, KS 66216 USA															
ENG. M. Gupta	6/18/13	<b>XE61S-N00 SERIES HC/ACMOS "S" LEVEL OSCILLATORS</b>															
Q. A. M. Gupta	6/18/13	FSC NO.							DWG. NO.								
CUST. ENG.		57051							XE61S-N00								
CUST Q A.		SCALE							N/A		SHEET			1 OF 9			

1. SCOPE: XE61S-N00, HC/ACMOS series, high reliability hybrid microcircuit crystal oscillators are designed, produced and tested by Xsis Electronics, Inc. as MIL-PRF-55310, Class "S" equivalent devices for use in advanced military, avionics and space applications. These devices are of hybrid microcircuit technology conforming to MIL-PRF-55310, Type 1, Class 2 oscillators.

2. APPLICABLE DOCUMENTS:

MIL-PRF-55310E	Oscillator, Crystal Controlled, General Specifications for
MIL-PRF-38534H	Hybrid Microcircuits, General Specifications for
MIL-STD-883H	Test Methods and Procedures for Microelectronics

3. REQUIREMENTS:

3.1 General: The individual item requirements shall be as specified herein.

3.2 Package: Kovar, 100 to 250 microinches nickel plated. Physical configuration shall be as shown in Figure 1. Thermal Resistance,  $\theta_{JC}$ : 30°C / Watt.

3.2.1 Lead finish: 50 to 70 micro-inches gold over 100 to 250 micro-inches nickel. Hot Solder tinning with Sn60/Pb40 solder per MIL-PRF-55310 is optional at an additional cost.

3.2.2 Weight: 5 Gms Max.

3.3 Hermeticity: Resistance welded, hermetically sealed, leak rate of  $1(10)^{-8}$  atm-cc/s Max.

3.4 Marking: As a minimum, the parts shall be marked with Xsis P/N, Xsis cage code, ESD symbol, date code and serial number.

3.5 Absolute Maximum Ratings: Unless otherwise specified, absolute maximum ratings shall be as follows:

Supply Voltage	-0.5 to +4.5 VDC
Operating Free-Air Temperature Range	-55°C to +125°C
Storage Temperature	-55°C to +125°C
Lead Soldering Temperature/Time	+250°C, 10 Seconds

3.6 Electrical Characteristics: See Table I

3.6.1 Total Dose Radiation: Hybrid Microcircuit Crystal Oscillators shall be capable of meeting the electrical characteristics of Para. 3.6 after being exposed to total ionizing dose radiation of 100 krad as per MIL-STD-883, method 1019.

3.7 Hybrid Elements:

3.7.1 Quartz Crystals: High grade cultured quartz crystal shall be used. As an option, Xsis will use premium Q swept quartz crystal at an additional charge, refer to part numbering example in paragraph 6 to specify swept quartz crystal. Crystal element evaluation shall be in accordance with MIL-PRF-55310.

3.7.2 Crystal Mounting: Crystal element shall be mounted at 4 points in such a manner as to provide adequate ruggedness and performance under extreme environments specified herein.

<b>XSIS ELECTRONICS, INC.</b> 12620 W. 63 <sup>rd</sup> St., Shawnee, KS 66216 USA	<b>FSC NO.</b> 57051	<b>DWG. NO.</b> XE61S-N00	<b>REV</b> A
	<b>SCALE</b> N/A	<b>SHEET</b> 2 OF 2	

- 3.7.3 Passive Elements: Established Reliability (ER) QPL components, failure level R minimum shall be used or element lot evaluation shall be as per MIL-PRF-55310, class S, or MIL-PRF-38534, Appendix C, Class K as applicable.
- 3.7.4 Microcircuit die shall be from lots that have passed the element evaluation per MIL-PRF-55310, Appendix B, Level S, except testing per Subgroup 5 is omitted. Subgroup 5 testing is circuit configuration dependent, therefore, it is more effectively performed at the oscillator level as explained in Paragraph 3.7.5 herein.
- 3.7.5 For Output Frequency up to 70 MHz, Microcircuit die used in the oscillator shall be from NSC/FC 54ACT family and must be from wafer lot that has been successfully tested in the oscillator for ionizing radiation of up to 100 krad. Xsis Electronics has also performed SET & SEL testing on the microcircuit die. Test reports are available on request. For output frequencies above 70 MHz, the microcircuit die shall be from 0.8  $\mu\text{m}$  BiCMOS Si family and must be from wafer lots that have been successfully tested in the oscillator for ionizing radiation of up to 100Krad and is known to be Single Event Latch-up immune for LET of up to 95 Mev-cm<sup>2</sup>/mg.
- 3.7.6 Workmanship, Rework and Process controls shall be in accordance with the requirements of MIL-PRF-55310.
- 3.7.7 Lot Traceability: Production lot for these oscillators shall be homogenous. Each element used in the production lot shall be traceable to a single lot. Swept quartz shall be traceable to the quartz bar, and its applicable processing details.
4. Quality Assurance Provisions: The quality assurance provisions shall be per MIL-PRF-55310, except as specified herein.
- 4.1 100% Screening: The 100% screening shall be performed as per Table II. PDA requirements for nondestructive bond pull and burn-in shall be as specified below.
- 4.2 PDA for Nondestruct Bond Pull: Unless otherwise specified, PDA shall be 2% of total number of wires or 1 wire whichever is greater.
- 4.3 PDA for Burn-in: Unless otherwise specified, PDA for burn-in shall be 2% or 1 oscillator whichever is greater and shall be applicable to +23 °C and/or +25 °C static tests only. In addition Delta Calculation shall be performed after Burn-in and shall count for PDA. All measured values for Delta Calculation shall be recorded. Parts that exceed the specified delta limits shall be rejected and be counted for PDA. Delta Calculation shall be performed at 2.5 VDC for the following parameters:
- |                   |                     |
|-------------------|---------------------|
| Input Current     | 10% change Maximum  |
| Output High Level | 10% change Maximum  |
| Output Low Level  | 0.1V change Maximum |
- 4.4 Group A inspection shall be in accordance with MIL-PRF-55310 for product level S.
- 4.5 Group B inspection ( 30 day aging ) shall be in accordance with MIL-PRF-55310 for product level S. In order to expedite delivery, by customer request, the aging test can be ended after 15 days if the amount of frequency aging is less than 50% of the 30 day specification limit.
- 4.6 Oscillators shall be capable of meeting group C inspection per MIL-PRF-55310. Generic group C inspection data on similar parts may be used to satisfy this requirement. When specified by the Customer, Xsis Electronics will perform Group C testing at an additional charge.

<b>XSIS ELECTRONICS, INC.</b> 12620 W. 63 <sup>rd</sup> St., Shawnee, KS 66216 USA	FSC NO. <b>57051</b>	DWG. NO. <b>XE61S-N00</b>	REV <b>A</b>
	SCALE <b>N/A</b>	SHEET <b>3 OF 2</b>	

4.7 Inspection and Test Data: Unless otherwise specified in the purchase order, the following Inspection and test data documentation shall be supplied with the parts. ( See Page 5 for the description of the Model Numbers other than XE61S )

**Model XE61S:**

Certificate of Conformance  
 Summary of Screening Test Results per Table II  
 PDA Calculations for Non-Destruct Bond Pull and Burn-in  
 Summary of Elements Lot Traceability  
 Electrical Tests before and after Burn-in  
 Group A Inspection Summary  
 Group B (30 day Aging) Data  
 Radiographic Inspection Certificate

**Model XE61H:**

Same as for **Model XE63S** except Group B (30 day Aging) Data

**Model XE61E:**

Certificate of Conformance  
 Summary of Screening Test Results per Table III  
 Summary of Elements Lot Traceability  
 Group A Inspection Summary  
 Radiographic Inspection Certificate, if required by the Purchase Order

**Model XE61B:**

Certificate of Conformance  
 Summary of Screening Test Results per Table III  
 Group A Inspection Summary  
 Radiographic Inspection Certificate, if required by the Purchase Order

**Model XE61P:**

Certificate of Conformance

4.8 The following test and inspection options are available at customer request.

Customer Source Inspection for Pre-Cap and Final  
 Group C Inspection per MIL-PRF-55310 on 4 or 8 units  
 DPA (Destructive Physical Analysis)  
 Life Test per MIL-STD-883, Method 1005, 1000 Hrs. at +125 °C  
 MIL-PRF-38534, Group B Inspection  
 MIL-PRF-38534, Group C Inspection

5.0 Preservation, Packaging and Packing: The oscillators shall be clean, dry and packaged in a manner to provide adequate protection against electrostatic discharge, corrosion, deterioration and physical damage during shipment.

<b>XSIS ELECTRONICS, INC.</b> 12620 W. 63 <sup>rd</sup> St., Shawnee, KS 66216 USA	<b>FSC NO.</b> 57051	<b>DWG. NO.</b> XE61S-N00	<b>REV</b> A
	<b>SCALE</b> N/A	<b>SHEET</b> 4 OF 2	

6.0 Part Numbering Example:

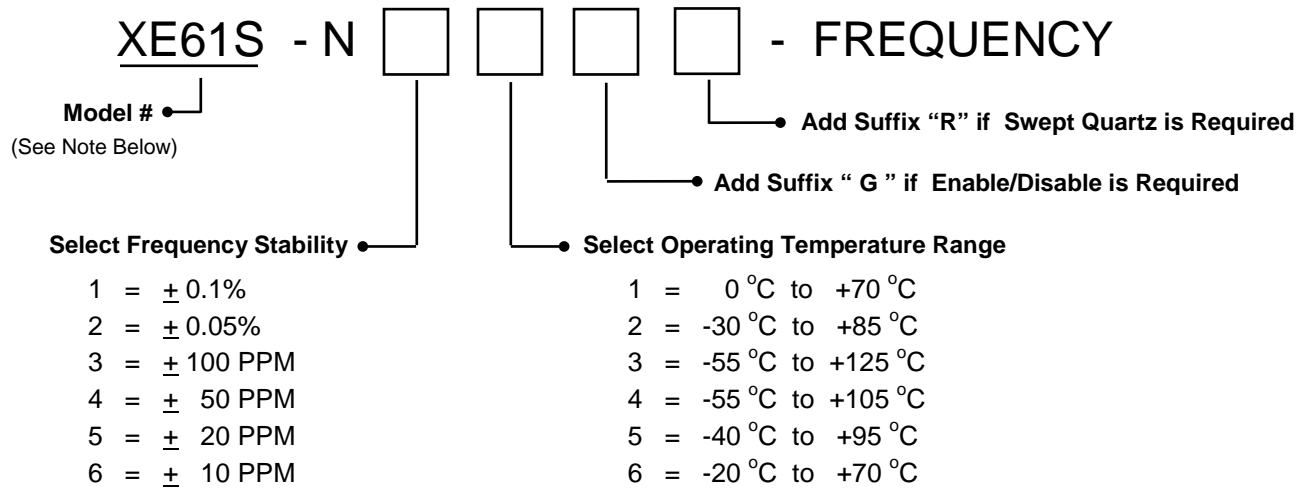

( Frequency Stability Options 5 & 6 are not available for all Temperature Range Options )

P/N Example: XE61S - N43 - 24.000 MHz = 24.000 MHz, Class "S" Oscillator, ± 50 PPM Frequency Stability over an operating temperature range of -55 °C to +125 °C,

**NOTE:** Besides model XE61S above, the following additional models are available for applications that can accommodate reduced level of Elements, Screening and Quality Conformance inspection:

**XE61H:** Model XE61H is same as Model XE61S except as follows:  
Group B inspection (30 day aging ) per MIL-PRF-55310 is not applicable

**XE61E:** Model XE61E uses the same design and elements as Model XE61S except as follows:  
100% screening is as per Table III herein  
PDA for Burn-in is 10% or 1 unit whichever is greater  
Delta measurements of paragraph 4.3 are not applicable  
Group A inspection is as per MIL-PRF-55310, Class B  
Group B inspection (30 day aging ) per MIL-PRF-55310 is not applicable

**XE61B:** Model XE61B is same as Model XE61E except as follows:  
Active and Passive Elements are as per MIL-PRF-55310, Class B. Microcircuit die is similar to the one used in Model XE61S but is not from radiation tested wafer lot.

**XE61P:** Model XE61P is a form, fit and function equivalent prototype of Model XE61S.  
Prototypes may use commercial grade elements and are not screened. Quality Conformance inspection is not applicable.

<p><b>XSIS ELECTRONICS, INC.</b> 12620 W. 63<sup>rd</sup> St., Shawnee, KS 66216 USA</p>	FSC NO. <b>57051</b>	DWG. NO. <b>XE61S-N00</b>	REV <b>A</b>
	SCALE N/A	SHEET 5 OF 2	

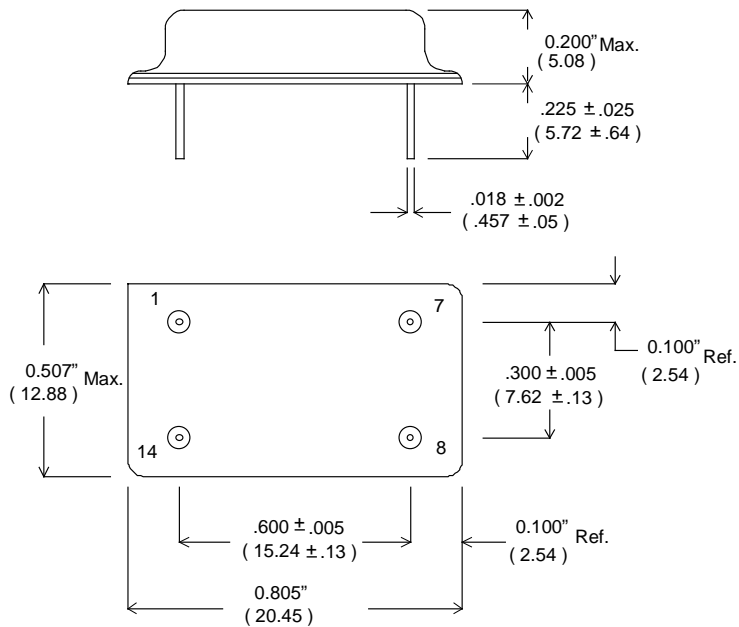

Dimensions: Inches (mm).

PIN #	FUNCTION
1	E/D (Optional)
7	GND/CASE
8	OUTPUT
14	B+
All Other	Missing

**E/D (Enable/Disable) Input:** A "Low" level at the input disables the Output into a high impedance state.

E/D Input has internal pull-up, it can be left floating or connected to Vdd.

Pin 1 is identified with a square corner

Figure 1 - Package Configuration & Pin Connections

**TABLE I – Electrical Characteristics**

Parameter	Spec. Limits
Frequency Range	125 Hz to 120 MHz
Frequency Accuracy at 23 °C	± 15 PPM Max.
Frequency Stability Vs Temperature	See Options in Paragraph 6.0
Operating Temperature Range	See Options in Paragraph 6.0
Input Voltage	+ 2.5 VDC ± 10%
Input Current at 2.5V ( no load )	
450.00 KHz to 5.00 MHz	2.5 mA Max.
5.01 MHz to 10.00 MHz	4 mA Max.
10.01 MHz to 20.00 MHz	6 mA Max.
20.01 MHz to 30.00 MHz	8 mA Max.
30.01 MHz to 40.00 MHz	12 mA Max.
40.01 MHz to 50.00 MHz	16 mA Max.
50.01 MHz to 70.00 MHz	25 mA Max.
70.01 MHz to 120.0 MHz	35 mA Max.
Output Waveform	Square Wave, HC/ACMOS
Output Duty Cycle	55/45% Max
Output Load	10K    15 pF
High Output Level	0.9 VDD Min
Low Output Level	0.1 VDD Max.
Rise & Fall Times	
450.00 KHz to 25.00 MHz	5 nS Max
25.01 MHz to 70.00 MHz	4 nS Max.
70.01 MHz to 120.0 MHz	3 nS Max.
Start-up Time	10 mS Max.
Phase Jitter	0.3 pS rms typ, (10 KHz to 20 MHz Integrated )
Frequency Stability Vs Supply Voltage	± 4 PPM Max. for 10% change in Voltage
Frequency Aging @ 70 °C	1.5 PPM Max. /30 days, 3 PPM Max. /year

Contact Xsis Engineering for any other special Requirements.

<b>XSIS ELECTRONICS, INC.</b> 12620 W. 63 <sup>rd</sup> St., Shawnee, KS 66216 USA	<b>FSC NO.</b> 57051	<b>DWG. NO.</b> XE61S-N00	<b>REV</b> A
	<b>SCALE</b> N/A	<b>SHEET</b> 7 OF 2	

**Table II - Models XE61S & XE61H, Screening (100%)**

Test - Inspection	Test Method – Condition
Nondestructive Bond Pull	MIL-STD-883, Method 2023
Internal Visual	MIL-STD-883, Method 2017, Level S
Stabilization Bake ( Prior to Seal ) <u>1/</u>	MIL-STD-883, Method 1008, Condition C ( +150°C ), 48 hours minimum
Thermal Shock	MIL-STD-883, Method 1011, Condition A
Temperature Cycling	MIL-STD-883, Method 1010, Condition B
Constant Acceleration	MIL-STD-883, Method 2001, Condition A Y <sub>1</sub> axis only ( 5000 G )
Seal ( Fine and Gross Leak )	MIL-PRF-55310, Para. 4.8.2.2.2
Particle Impact Noise Detection ( PIND )	MIL-STD-883, Method 2020, Condition A
Radiographic Inspection	MIL-STD-883, Method 2012, Class S
Electrical Tests: Record all measurements.  Input Current Output Frequency Output Voltage Levels Output Rise & Fall Times Output Duty Cycle	Nominal Supply Voltage, Specified load, +23 °C  MIL-PRF-55310, Para. 4.8.5 MIL-PRF-55310, Para. 4.8.6 MIL-PRF-55310, Para. 4.8.21.3 MIL-PRF-55310, Para. 4.8.22 MIL-PRF-55310, Para. 4.8.23
Burn-in ( load )	+125 °C, Nominal Supply Voltage and Burn-in load, 320 Hours Minimum
Electrical Tests: Record all measurements.  Input Current Output Frequency Output Voltage Levels Output Rise & Fall Times Output Duty Cycle	Nominal and Extreme Supply Voltages, Specified load, +23 °C and operating temperature extremes,  MIL-PRF-55310, Para. 4.8.5 MIL-PRF-55310, Para. 4.8.6 MIL-PRF-55310, Para. 4.8.21.3 MIL-PRF-55310, Para. 4.8.22 MIL-PRF-55310, Para. 4.8.23

1/ Vacuum bake and maintain oscillators in dry nitrogen per MIL-PRF-55310.

<b>XSIS ELECTRONICS, INC.</b> 12620 W. 63 <sup>rd</sup> St., Shawnee, KS 66216 USA	<b>FSC NO.</b> 57051	<b>DWG. NO.</b> XE61S-N00	<b>REV</b> A
	<b>SCALE</b> N/A	<b>SHEET</b> 8 OF 2	



Table III - Models XE61E & XE61B, Screening (100%)

Test - Inspection	Test Method – Condition
Nondestructive Bond Pull	MIL-STD-883, Method 2023
Internal Visual	MIL-STD-883, Method 2017, Level B
Stabilization Bake ( Prior to Seal ) <u>1/</u>	MIL-STD-883, Method 1008, Condition C ( +150 °C ), 24 hours minimum
Temperature Cycling	MIL-STD-883, Method 1010, Condition B
Constant Acceleration	MIL-STD-883, Method 2001, Condition A Y <sub>1</sub> axis only ( 5000 G )
Seal ( Fine and Gross Leak )	MIL-PRF-55310, Para. 4.8.2.2.2
Particle Impact Noise Detection ( PIND )	MIL-STD-883, Method 2020, Condition A
Electrical Tests:  Input Current Output Frequency Output Voltage Levels Output Rise & Fall Times Output Duty Cycle	Nominal Supply Voltage, Specified load, +23 °C Verify all parameters  MIL-PRF-55310, Para. 4.8.5 MIL-PRF-55310, Para. 4.8.6 MIL-PRF-55310, Para. 4.8.21.3 MIL-PRF-55310, Para. 4.8.22 MIL-PRF-55310, Para. 4.8.23
Burn-in ( load )	+125 °C, Nominal Supply Voltage and Burn-in load, 160 Hours Minimum
Electrical Tests:  Input Current Output Frequency Output Voltage Levels Output Rise & Fall Times Output Duty Cycle	Nominal Supply Voltage, Specified load, +23 °C and verify frequency at temperature extremes.  MIL-PRF-55310, Para. 4.8.5 MIL-PRF-55310, Para. 4.8.6 MIL-PRF-55310, Para. 4.8.21.3 MIL-PRF-55310, Para. 4.8.22 MIL-PRF-55310, Para. 4.8.23

1/ Vacuum bake and maintain oscillators in dry nitrogen per MIL-PRF-55310.